



Multi-Hopper Repackaging for Shipment

The following repackaging procedures are required for preparing the multi-hopper component of the Entrust Artista® CR825 or CE875 Instant Issuance System for shipment.

1. Disable the printer.



Disabling the printer is only required when repacking the printer for shipment.

- a. Press the USER button on the printer until **Suspended Menu Available** displays on the LCD panel, and then press ENTER to ENTER the main menu.

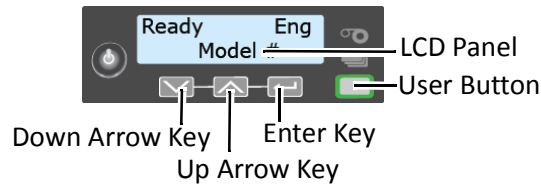

- b. Press the down arrow key until **Activate** displays on line 2 of the LCD panel.

Press ENTER to enter the **Activate** menu.



- c. Press the down key until **Disable** displays on line 2 of the LCD panel.

Press ENTER to enter the **Disable** menu.



- d. Enter the code used to activate the system.



- e. Press the up and down arrow keys to cycle through the alphabetic and numeric characters. Press ENTER to select each character that matches the 8-digit numeric code. When "Request Success" displays on line 2 of the LCD panel, the system is inactivated.

2. Press the power button to power off the printer.

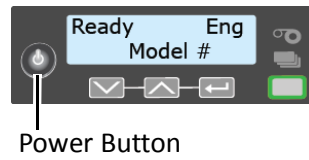

The front panel on the printer powers off.



Caution: Wait until all the lights on the front panel go off to make sure that the printer power is off.

3. Unplug the printer power cord from the power supply.
4. Remove the multi-hopper supplies.
 - a. Unlock the multi-hopper.
 - b. Push the hopper lock slider to the unlocked position.
 - c. Move the three lock rods over to the unlocked position.

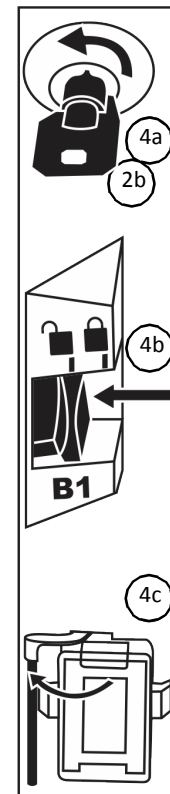
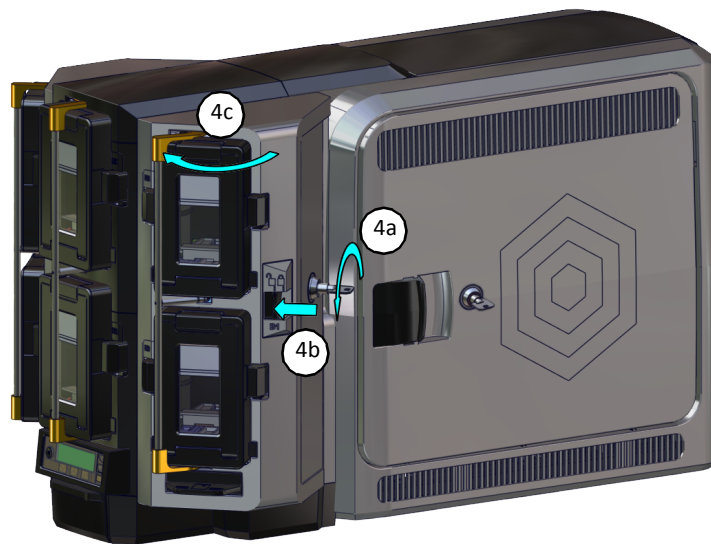

- d. Remove all cards from the six hoppers.

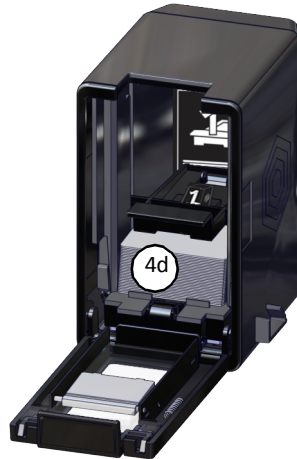

- e. Move the three lock rods over to the locked position.
 - f. Pull the hopper lock slider to the locked position.
 - g. Lock the multi-hopper.
5. Remove the multi-hopper from the printer.
- a. Unlock and open the printer.
 - b. Remove the C1 supply cartridge.
 - c. Push in on the multi-hopper retaining tab located at the inside front of the printer frame.

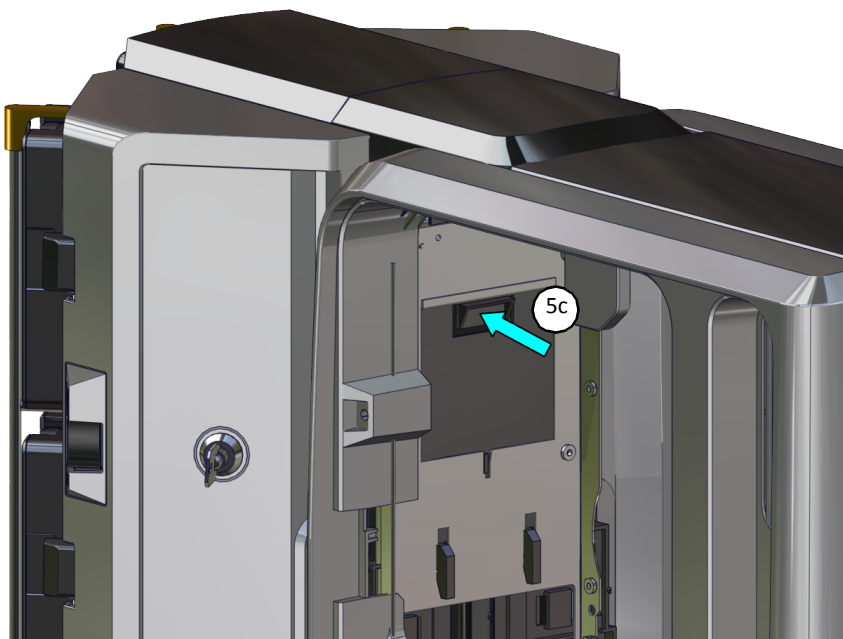

- d. Lift up slightly on the multi-hopper component to release the mounting hooks from the printer frame.
- e. Pull out to remove the multi-hopper.

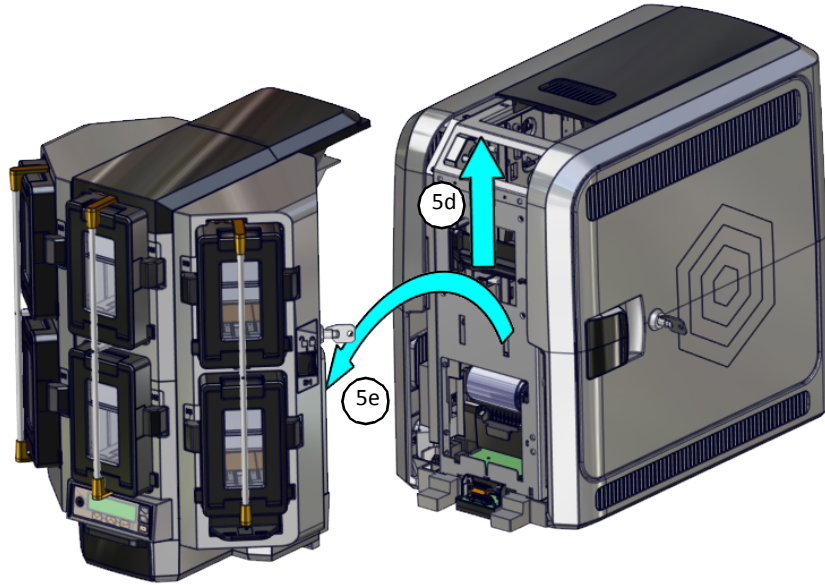

- 6. Pack and secure the multi-hopper.
 - a. Push down to fold the transition enclosure on the multi-hopper.

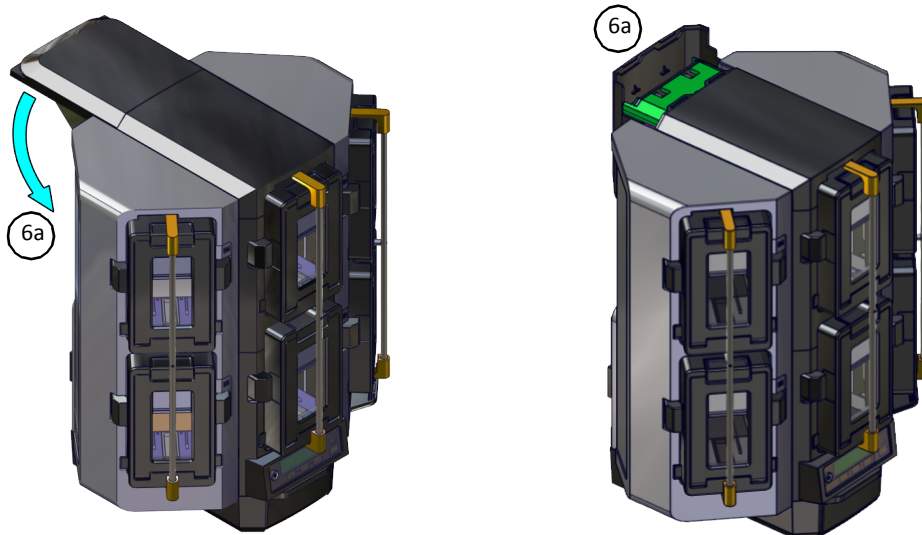

- b. Insert the restraining pins saved from the printer's installation at the top and bottom positions of the multi-hopper to secure the elevator and shuttle.

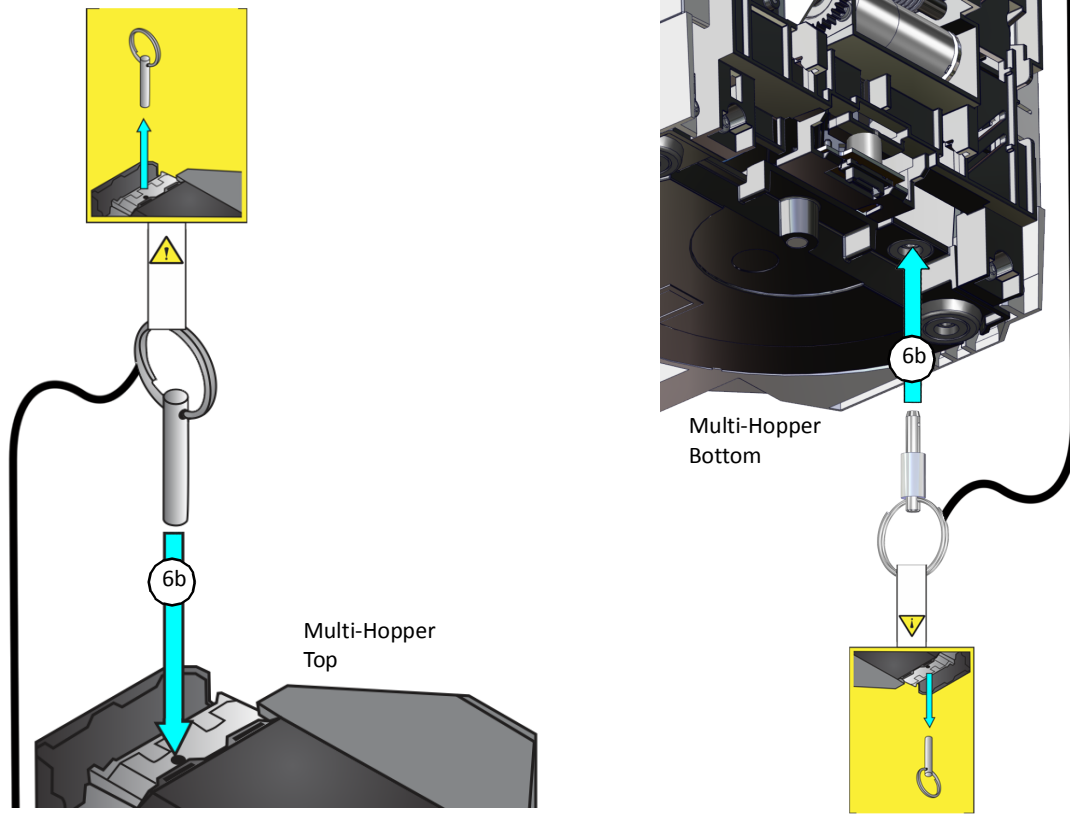

c. Place the multi-hopper into the bottom foam cap.

 Place the multi-hopper into a plastic bag, if available.

d. Lift the multi-hopper with the bottom foam cap into the shipping carton.

e. Place the top foam cap in the shipping carton on top of the multi-hopper.

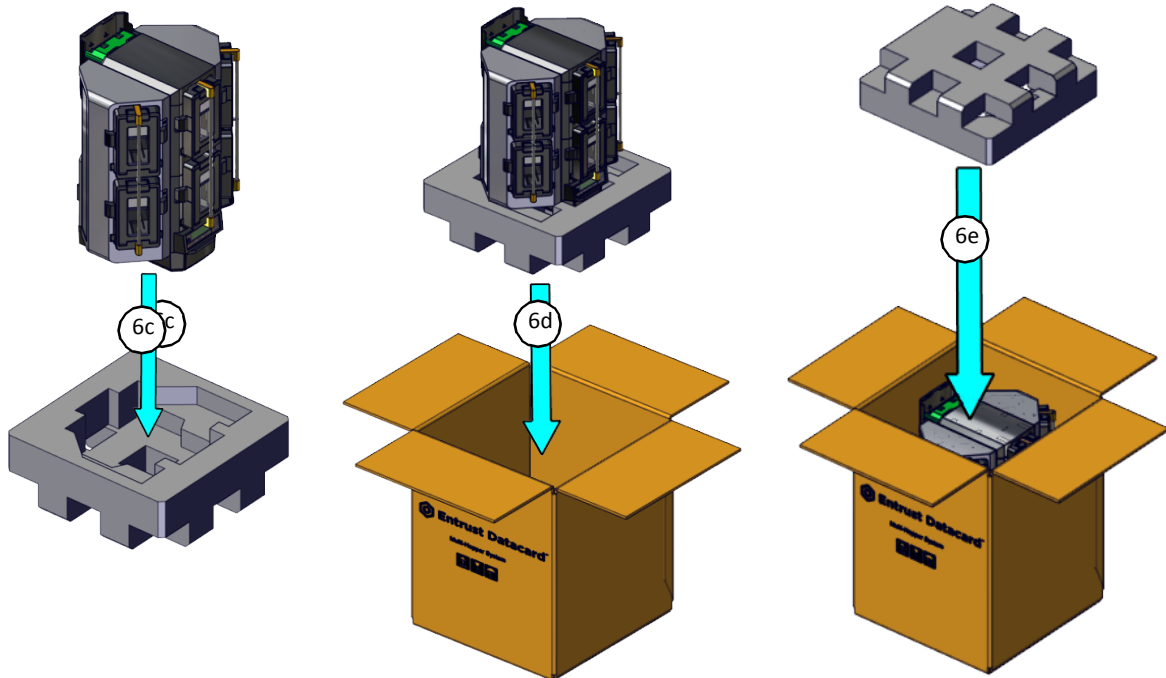

f. Secure the shipping carton with shipping tape.

Entrust, Sigma and the hexagon design are trademarks, registered trademarks and/or service marks of the Entrust Corporation in the United States and other countries.
All other product names are the property of their respective owners.
© 2017-2021 Entrust Corporation. All rights reserved.