



ENTRUST

Installation and Administrator's Guide

Entrust Artista® CR825 Instant Issuance System
Entrust Artista® CR875 Instant Issuance System

April 2021

527748-001, Rev. G

Notice

Please do not attempt to operate or repair this equipment without adequate training. Any use, operation or repair you perform that is not in accordance with the information contained in this documentation is at your own risk.

Trademark Acknowledgments

Entrust, Sigma and the hexagon design are trademarks, registered trademarks and/or service marks of the Entrust Corporation in the United States and other countries.

Datacard is a registered trademark and service mark of Entrust Corporation in the United States and other countries.

MasterCard is a registered trademark of MasterCard International Incorporated.

Visa is a registered trademark of Visa International Service Association.

All other product names are the property of their respective owners.

Proprietary Notice

The design and information contained in these materials are protected by US and international copyright laws.

All drawings and information herein are the property of Entrust Corporation. All unauthorized use and reproduction is prohibited.

Entrust Corporation

1187 Park Place
Minneapolis, MN 55379
Phone: 952-933-1223
Fax: 952-933-7971
www.entrust.com

© 2016-2021 Entrust Corporation. All rights reserved.

Revision Log

Revision	Date	Description of Changes
01	May 2016	Beta release of this document.
A	November 2016	First release of this document.
G	April 2021	Updated document branding.
B	August 2017	Added new cleaning procedures and multi-hopper support.
C	September 2017	Updated multi-hopper information.
D	July 2018	Added modular single hopper support and general updates.
E	March 2019	Updated the printer cleaning instructions.
F	January 2020	Removed the modular single hopper and the Compliance information.
G	April 2021	Updated document branding.



Contents

Chapter 1: Printer Installation	1
PC Requirements	1
Ethernet Requirements	2
Electrical Requirements	2
Site Requirements	3
Printer Dimensions	3
Single-Hopper Printer	3
Multi-Hopper Printer	4
Clearance Requirements	5
Single-Hopper Printer	5
Multi-Hopper Printer	5
Operating Environment	6
Storage Environment	6
Secure Printing Requirements	7
Install the Printer	8
Unpack the Printer	9
Secure the Printer (Optional)	10
Use the Optional Cable Lock	10
Use the Bolt-Down Openings	11
Install the Multi-Hopper	13
Unpack the Multi-Hopper	13
Prepare the Multi-Hopper	14
Assemble the Multi-Hopper Printer	15
Plug In and Power On the Printer	16
Activate the Printer	17
Clean the Printer	19
Single-Hopper Printer	20
Multi-Hopper Printer	20
Start the Cleaning Cycle	21
Install Supplies	22
Install the Ink Ribbon	22
Install the Cleaning Sleeve	24
Install the Retransfer Film	25
Load Cards	27
Single-Hopper Printer	27
Multi-Hopper Printer	28
Install a Large Output Hopper	29
Connect to the Printer	31
Set the Printer Network IP Address	32
Set a Static IP Address	32
Test the IP Address Using a Local Network	35

Print a Test Card	38
Set Up Network Access	39
Verify Network Communication	39
Chapter 2: Elements of Card Design	41
Basic Card Design	41
Printing Design	42
Color Printing	42
Color Management	43
Print Text in Color	43
Print Graphics in Color	43
Monochrome Printing	44
Monochrome Printing with Full-Color Ribbon	44
Print Text in Monochrome	44
Print Bar Codes	45
Bar Code Guidelines	45
Test Bar Codes	46
Card Design Changes That Affect Bar Codes	46
Apply a Second Layer of Retransfer Film	47
Non-Printing Areas	48
Standard Magnetic Stripe Non-Printing Area	49
Standard Smart Card Non-Printing Area	49
Custom Non-Printing Areas	49
Card Layout	50
Image Size	50
Backgrounds	51
Image Placement	51
Magnetic Stripe Design	52
Magnetic Stripe Data Formats	52
Three-Track Option (ISO/IAT)	52
Single-Track Option (JIS)	53
Magnetic Stripe Coercivity	54
Smart Card Processing	54
Smart Card Processing Requirements	54
Smart Card Codes on the Printer Labels	55
Single-Wire Smart Card	55
Embossing and Indenting Design	56
Settings for Card Design in Printer Manager	56

- Chapter 3: Printer Manager 59**
- Printer Manager 59**
- Printer Manager User Access Levels 60
 - WebUser 60
 - WebAdmin 60
 - WebService 60
- Access Printer Manager 61
- Printer Manager Settings 62
- Print a Printer Manager Page 62
- Use Printer Manager 63**
- Status Menu 64
- Printer Setting Menu 66
 - Communication 70
 - ActivityLog 74
 - Behavior 76
 - VitalProductData 79
 - FrontPanel 80
 - Print 81
 - Pick 83
 - Transport 84
 - VertTransport 84
 - Flipper 85
 - BarcodeReader 86
 - CardStock 87
 - HeatRoller 90
 - Retransfer 91
 - Debower 92
 - SmartCard 92
 - MagStripeGeneral 93
 - MagStripeCustomTrack 1–3 95
 - Emboss 97
 - Multihopper 98
 - Manufacturing 98
 - WifiNetworkStationSetup 98
 - WifiModes 100
 - Update Password 102
 - Set Job Queue State 103
- TroubleShooting Menu 104
 - SSA Test 105
 - Activity Log 105
 - Reset Log 105
 - Reset Counters 105
 - Printer Reset 105
- Embosser Menu 106
 - Audit Log 106

Reset Log	106
Maintenance Menu	107
Cleaning	107
Updates	109
Log Out Menu	109
Chapter 4: Supplies and Parts	111
Printer Supplies	112
Ink Ribbon	112
Retransfer Film	112
Supply Storage Guidelines	113
Cards	114
Card Size	114
Card Material	114
Card Surface Finish	114
Card Irregularities	114
Card Die Cutting	115
Card Handling	115
Card Storage	116
Cleaning Supplies	116
Replacement Parts	117
Ink Ribbon Cartridge	117
Retransfer Film Cartridge	117
Cleaning Spindle	117
Optional Equipment	117
Large Output Hopper	117
Cable Lock	117
Cables and Power Supplies	118
Data Cable	118
Printer Power Supply	118
Power Cords	119

- Appendix A: CE875 Instant Issuance System A-1**
- Introduction A-1**
- Site Requirements A-2**
 - System Dimensions. A-2
 - Single-Hopper System A-2
 - Multi-Hopper System A-3
 - Clearance Requirements A-4
 - Single-Hopper System A-4
 - Multi-Hopper System A-5
- Electrical Requirements A-5**
- Unpack the Embosser. A-6**
- Remove Shipping Items A-7**
- Secure the Embosser A-7**
 - Use the Embosser Bolt-Down Openings A-8
 - Use the Embosser Cable Lock A-10
- Assemble the Printer and Embosser A-11**
- Connect the Power Cords A-12**
- Connect the System to the Network A-12**
- Load Embosser Supplies. A-13**
 - Load the Indent Ribbon Cartridge A-13
 - Load the Topping Foil Cartridge A-15
- Power On the System A-16**
- Embosser Supplies A-17**
 - Indent Ribbon A-17
 - Topping Foil A-17
 - Embosser Supply Storage Guidelines A-18
- Embosser Replacement Parts A-19**
 - Indent Ribbon Cartridge A-19
 - Topping Foil Cartridge. A-19
 - Embosser Power Supply A-19
 - Power Cords. A-19

Chapter 1: Printer Installation



This chapter describes system requirements and provides setup instructions for the Entrust Artista CR825™ and CE875™ Instant Issuance Systems.

Your installation may have additional requirements for a card production environment. Consult your system administrator to determine the optimum location for card production.

PC Requirements

Use a PC that meets or exceeds the following:

- A 32- or 64-bit processor, running at 2 GHz or faster.
- 4 GB or more memory (RAM) and at least 1 GB free space on the hard drive.
- One of the following operating systems:
 - Windows 10, 32- or 64-bit
 - Windows 8.1, 32- or 64-bit
 - Windows 7, 32- or 64-bit
 - Windows Server 2016
 - Windows Server 2012, R2, 64-bit
 - Windows Server 2008, 64-bit
- An Ethernet network connection.
- Entrust Adaptive Issuance™ Instant Financial Issuance (formerly CardWizard®) software.

Ethernet Requirements

You can connect many network printers to one PC. The maximum number of printers depends on the capacity of the network to deliver data to the printer.

The following components are required to install a printer on a network:

- An Ethernet network that uses the TCP/IP protocol and can run at one of the following: 1Gbase-T (1 gigabyte per second) or 100base-T (100 megabits per second).
- An Ethernet cable to connect the printer to the network. An Ethernet cable is not supplied with the printer.
- A PC that meets the “[PC Requirements](#)” on [page 1](#), and is connected to, and communicating with, the network.

Electrical Requirements

The power supply detects the input voltage and works within the range stated.

Printer Model	Electrical Requirements	
	Input	Output
CR825	85–230VAC/47-63 Hz/1.2Amp	24V/6.6Amp/160W
CE875	Refer to Appendix A: "CE875 Instant Issuance System" .	

Site Requirements

Set up and use the printer in an environment that meets the following requirements.

- Use a single-phase, 3-wire, grounded receptacle.
- Place the system and its supplies in a clean office environment, keeping paper and foreign materials off of the equipment.
- Place the printer on a sturdy, level surface.
- Place the printer away from direct sunlight.
- Do not place the printer near heating ducts, fans, or other air vents.
- Do not use the printer for purposes other than the intended use.
- Provide space for the printer and for clearance around the printer. The printer dimensions and clearance area are shown in the following sections.

Printer Dimensions

The external printer dimensions are shown in the following illustrations.

Single-Hopper Printer



Multi-Hopper Printer

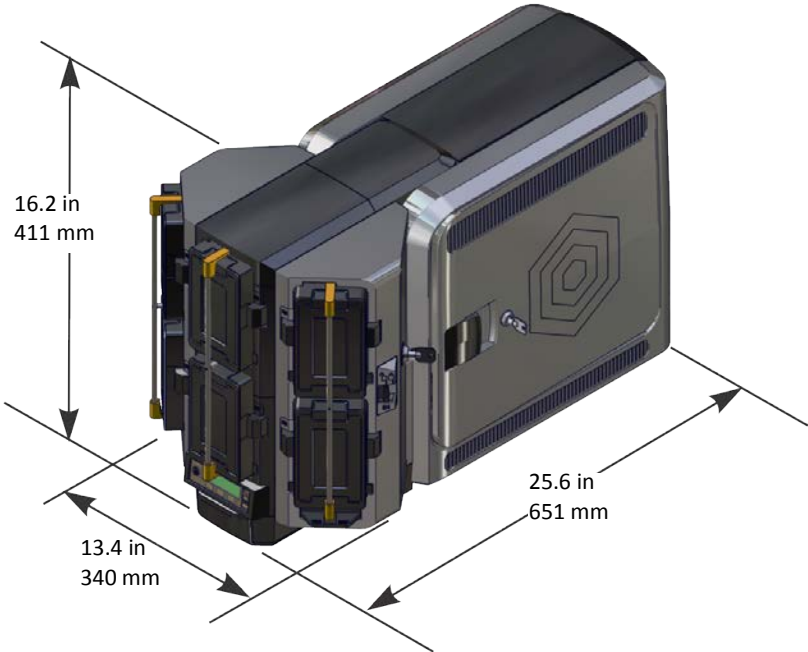

Clearance Requirements

The following measurements show the printer dimensions when the system access doors are open and the power cord is connected. We recommend that you provide at least 3 inches (76.2 mm) of additional clearance around the system to maintain access to the power cord and data cables, and to allow you to load and remove cards and supplies.

Single-Hopper Printer

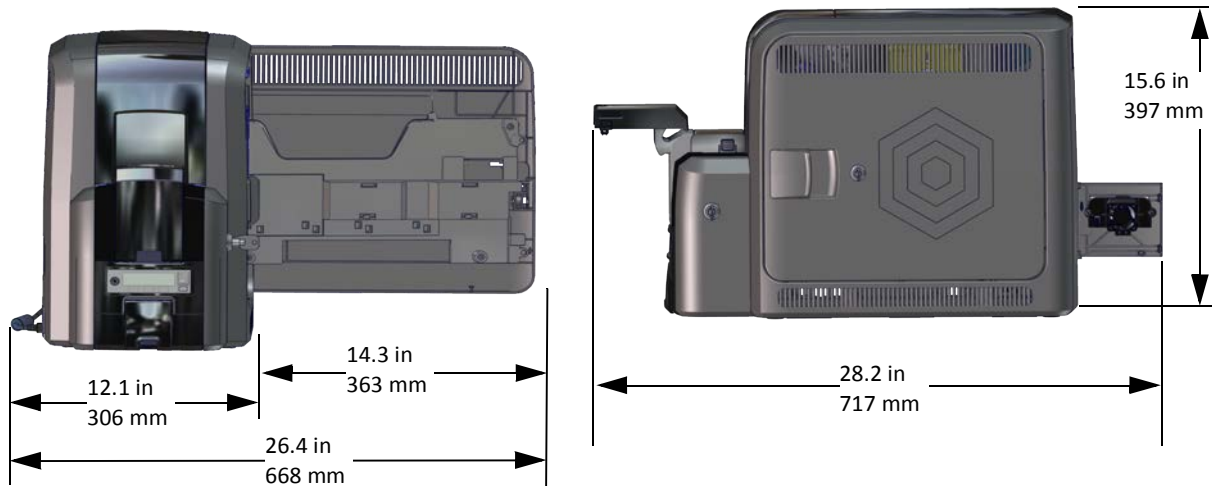

Options, such as a large output hopper, change the dimensions of the printer. Additional clearance is required when using these options.

Multi-Hopper Printer

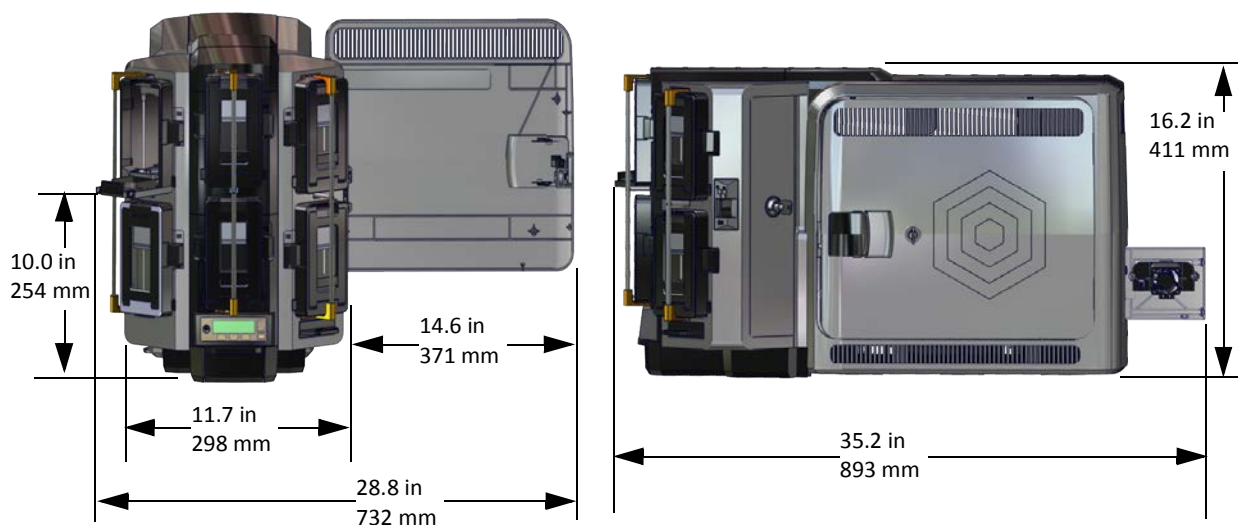

Operating Environment

Use the following guidelines when operating the printer:

Operating temperature	50° to 95°F (15° to 35°C)
Operating humidity	20% to 80% non-condensing

Using the printer in areas that are cooler than the recommended temperatures can cause retransfer errors. Using the printer in areas that are warmer than the recommended temperatures can cause cards to warp and retransfer film errors.

Storage Environment

If you are storing the printer for an extended length of time, remove the ink ribbon and retransfer film, and use the following storage guidelines:

Storage temperature	5° to 141°F (-15° to 60°C)
Storage humidity	10% to 90% non-condensing

Secure Printing Requirements

Secure printing consists of encrypting print commands and card data and transmitting the information securely from the PC to the printer. Printers are shipped with both non-secure (DPCL and DPCL2) and secure (DPCL2Secure) communication protocols enabled. You can enable or disable communication protocols using Printer Manager. Refer to “Behavior” on page 56 for more information about how to specify the printer security settings.

The printer uses TLS for encryption. The default setting restricts connections to the printer to TLS 1.2 to provide maximum security. However, you can change the minimum TLS version, if necessary to allow TLS1.1. To change the TLS encryption version requires Webservice access to Printer Manager. Contact your system administrator or your service provider.

If your card production site requires secure printing, use the following:

- An Entrust Datacard CR825 instant issuance system with secure printing (DPCL2Secure) enabled and both DPCL and DPCL2 disabled.
- An Entrust Datacard CE875 instant issuance system with secure printing (DPCL2Secure) enabled and both DPCL and DPCL2 disabled.
- The Printer Manager **Communications > MinTLSVersion** value set to TLS1_2. This restricts secure communication to TLS 1.2-compatible encryption.



MinTLSVersion is a Webservice access-level setting. Contact your system administrator or service provider to change the setting, if necessary.

- The Printer Manager **Behavior > Plugin** setting is set to **Disabled**. Refer to “Behavior” on page 76.
- A PC that meets the PC requirements listed in “PC Requirements” on page 1.
- An Ethernet connection that meets the requirements listed in “Ethernet Requirements” on page 2.
- A current browser.
- The current version of printer firmware. New firmware releases add patches for known security vulnerabilities.

If you use Entrust Adaptive Issuance™ Remote Monitoring and Management Software to manage your printers, you can disable the printer’s native configuration interface, Printer Manager, by changing the **Behavior > WebServerSecure** setting to **Disabled**. This prevents unauthorized access to the printer and provides a higher level of security. Refer to “[Behavior](#)” on [page 76](#).



Caution: Do not disable the WebServerSecure setting unless you use Remote Monitoring and Management software. You cannot re-enable Printer Manager to manage the printer if you do not use Remote Monitoring and Management software.

Install the Printer

The following sections describe the setup process when you first install the printer.

The printer ships with a standard 125-card input hopper. If you ordered the printer with an optional multi-hopper, the printer is manufactured without an input hopper. This allows you to install the multi-hopper with six input hoppers, each with a 125-card capacity.

An optional 125-card output hopper also is available and can be installed without tools on single-hopper CR825 systems.

The following sections show the printer with a single hopper. Printer option-specific information is noted, where necessary.

- [Unpack the Printer on page 9](#)
- [Secure the Printer \(Optional\) on page 10](#)
- [Install the Multi-Hopper on page 13](#)
- [Plug In and Power On the Printer on page 16](#)
- [Activate the Printer on page 17](#)
- [Clean the Printer on page 19](#)
- [Install Supplies on page 22](#)
- [Install a Large Output Hopper on page 29](#)

Unpack the Printer

1. Remove the printer from the shipping carton. The accessories tray holds the printer power supply and power cord, the cleaning roller spindle, CDs, and the printer documentation.

 If the printer is ordered with the optional multi-hopper, the printer is shipped without an input hopper. The multi-hopper is shipped separately from the printer. Refer to [“Install the Multi-Hopper”](#) on page 13.

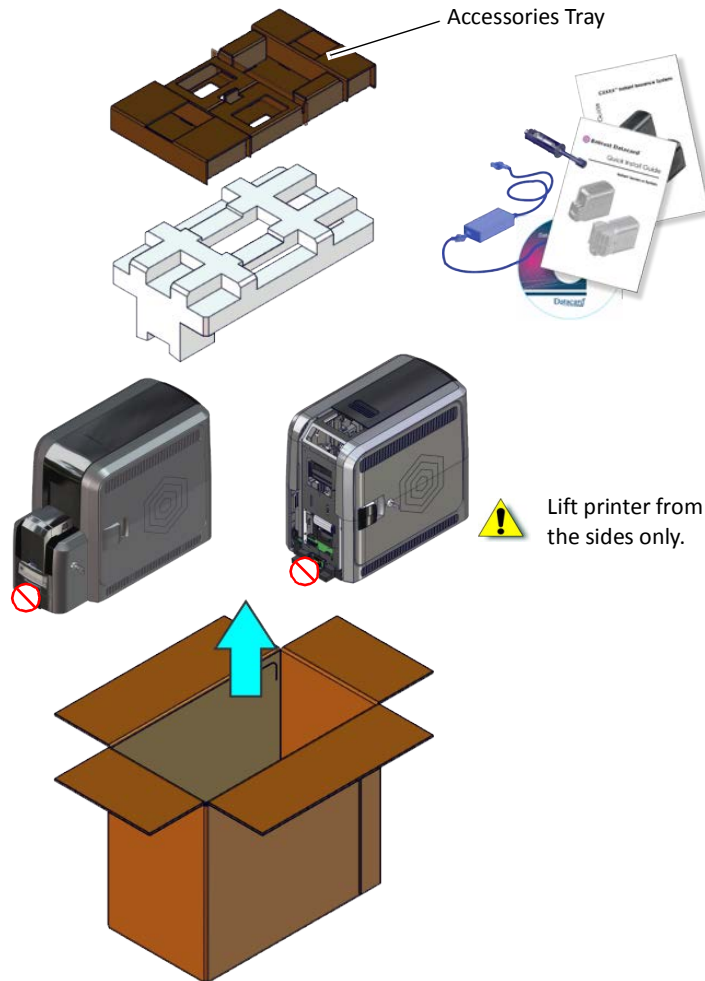

 Save the shipping cartons and packing materials. They are required if you need to store, move, or return the system for service.

2. Place the printer on the selected work surface. Make sure that the surface meets the requirements described in [“Site Requirements”](#) on page 3.

 The CE875 instant issuance system includes an embosser. refer to [“Unpack the Embosser”](#) on page A-6 for information about how to prepare the embosser.

Secure the Printer (Optional)

 This procedure is optional.

You can secure the printer using one of the following:

- An optional cable lock (refer to [“Use the Optional Cable Lock”](#)).
- The bolt-down openings in the bottom of the printer (refer to [“Use the Bolt-Down Openings”](#) on [page 11](#)).

Use the Optional Cable Lock

The cable lock is a user-installed feature that does not require special tools to install. The package contains a cable lock, instructions, and a metal security plate. The security plate is installed in the printer and is designed to accommodate the T-bar of the cable lock.

- The cable lock is available with either a key or combination lock
- If you have a CE875 instant issuance system, the cable lock can be installed in the embosser component of the system. Refer to [“Use the Embosser Cable Lock”](#) on [page A-10](#).

1. Prepare the printer by installing the metal security plate:
 - a. Tip the printer on its right side.
 - b. Locate the security plate receptacle on the underside of the printer toward the back left side.
 - c. Insert the security plate into the receptacle with the open end toward the printer.
 - d. Insert the T-bar of the cable lock through the printer opening into the security plate.
2. Follow the instructions included with the cable lock to complete the installation.

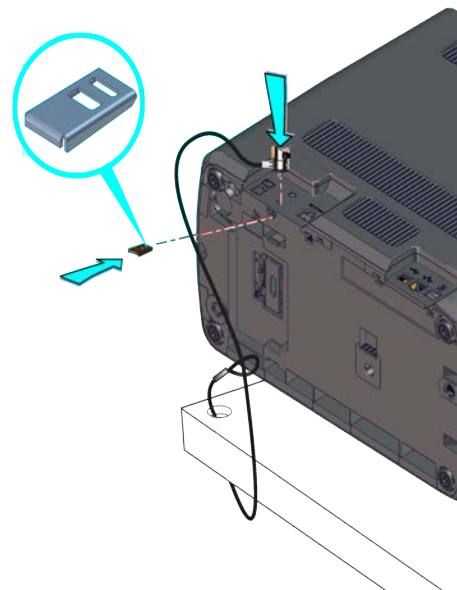

Use the Bolt-Down Openings

The printer includes bolt-down openings that you can use to secure it to a mounting surface.

You need the following supplies:

- The bolt-down kit (part no. 512969-001) contains two M6 well nuts.
- Two M6 (6 mm) screws, purchased separately.

The length of the screws you need depends on the thickness of the mounting surface. The screw length is the surface thickness + 0.75 inch (20 mm).

- Two M6 washers, purchased separately.
 - 1/4-inch (7 mm) drill bit.
1. Drill two holes in the mounting surface following the dimensions and requirements shown in the following figure:

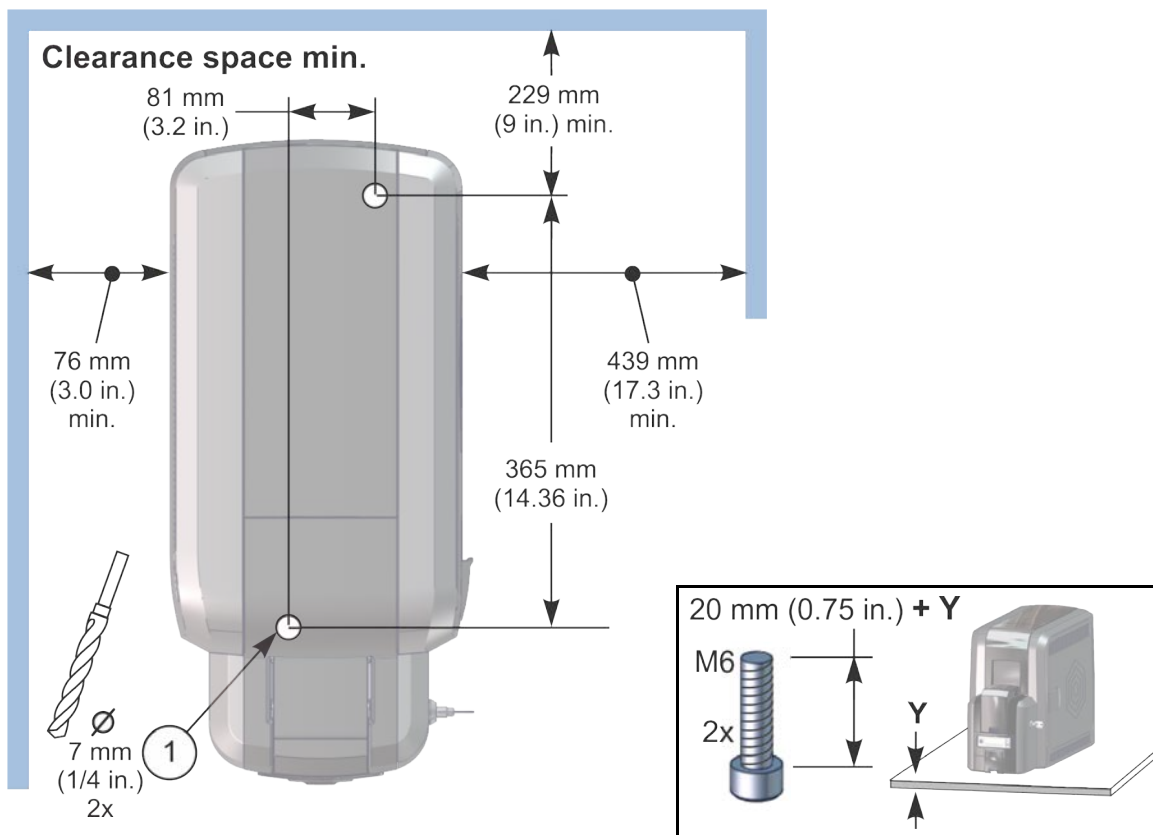

2. Carefully tip the printer onto its left side (the side without the access door).
3. Insert the M6 well nut threaded inserts into the bolt-down openings on the bottom of the printer.
4. Return the printer to its upright position and position it over the holes that are drilled in the mounting surface.

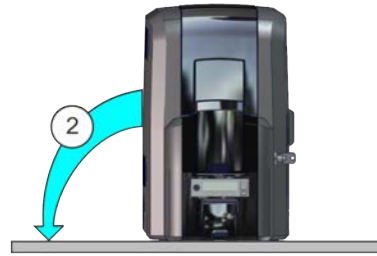

5. Secure the printer to the mounting surface.
 - a. Place a flat washer on each of the screws beneath the mounting surface.
 - b. Insert the M6 screws through the holes in the mounting surface and into the well nuts in the bottom of the printer.
 - c. Tighten the screws securely.

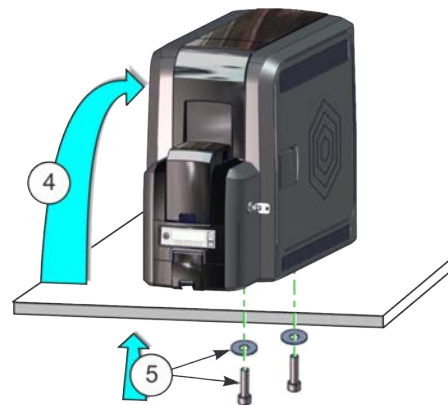
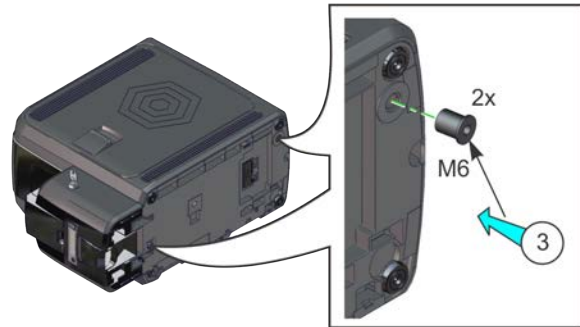

If your system includes an embosser, you can secure the embosser to a mounting surface. Refer to [“Use the Embosser Bolt-Down Openings”](#) on page A-8.

Install the Multi-Hopper

Use the following information if you purchased the optional multi-hopper.

Unpack the Multi-Hopper

1. Remove the multi-hopper from the shipping carton.

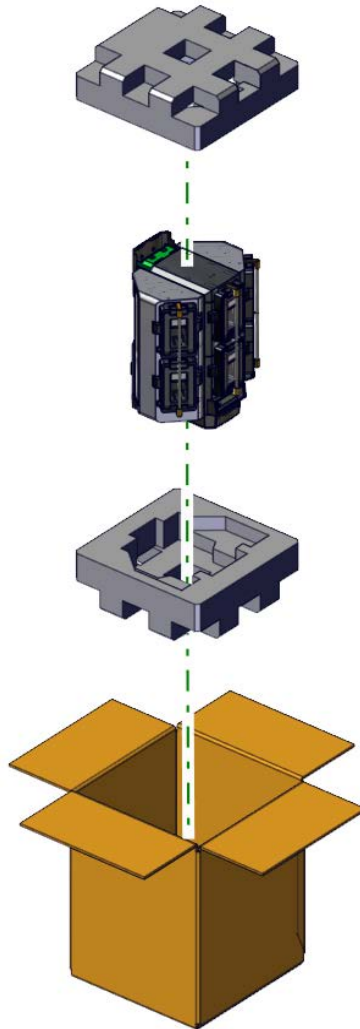

2. Continue with [“Prepare the Multi-Hopper”](#) on page 14.

Prepare the Multi-Hopper

The multi-hopper ships with the enclosure transition folded down with a restraining pin holding it in position. A second restraining pin is inserted into the bottom of the multi-hopper.

1. Pull the top restraining pin straight up from the multi-hopper to remove it from the enclosure transition. Pull the bottom pin straight down from the multi-hopper. The bottom pin includes a spacer.



Save the restraining pins after removing them from the multi-hopper. They are required if you need to repackage and return the multi-hopper for service.

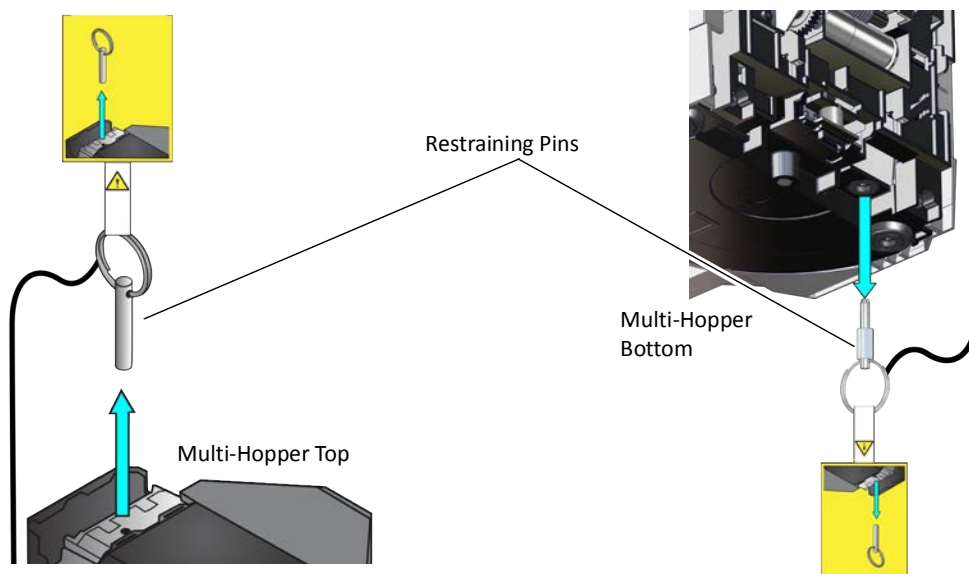

2. Rotate the enclosure transition 90° so that it aligns with the top of the multi-hopper.

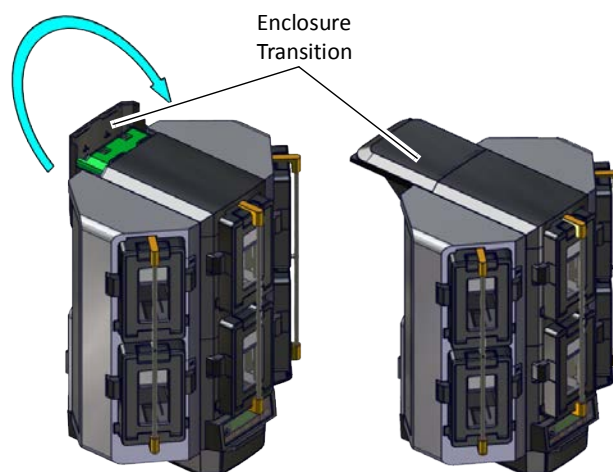

3. Continue with [“Assemble the Multi-Hopper Printer”](#) on page 15.

Assemble the Multi-Hopper Printer

- 1. Match the two large hooks on the back center of the multi-hopper with the two slots on the printer frame.

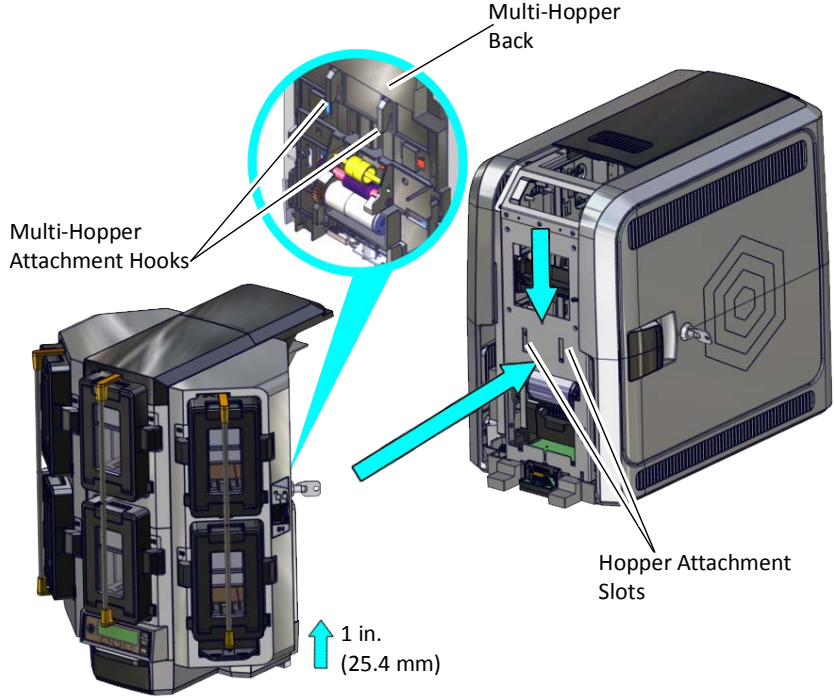

- 2. Lift the multi-hopper approximately one inch (25.4 mm) and push it in slightly to engage the hooks into the frame.
- 3. Push down to secure the multi-hopper to the printer.

Plug In and Power On the Printer

1. Connect the printer power supply to the printer. Then, connect the power cord to the power supply.

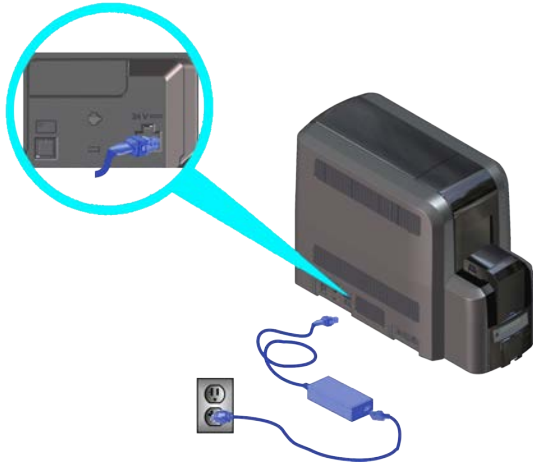

2. Plug the power supply cord into the facility power source.

The front panel of the printer provides the controls you need to operate the system. Refer to the printer's *User's Guide* for complete information about using the front panel.

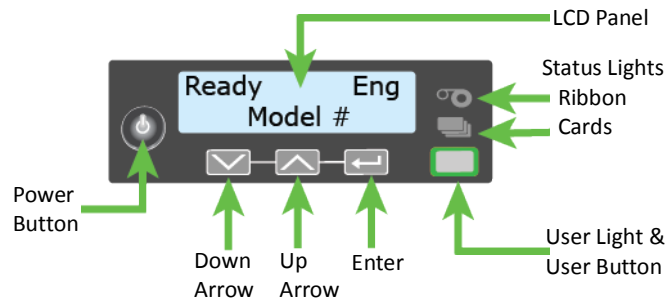

Press the POWER button on the front panel to power on the printer.



The printer may or may not require activation.

- If **Print job queue is deactivated** displays on the LCD panel, continue with [“Activate the Printer”](#) on page 17.

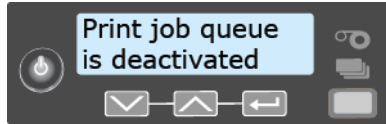

- If **Ready** displays on the LCD panel, continue with [“Clean the Printer”](#) on page 19.

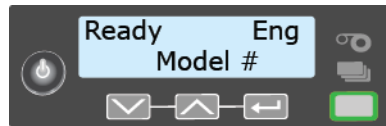

Activate the Printer

If the printer requires activation, obtain an activation code from Entrust Datacard technical phone support at 1-800-328-3996. Do this before starting the activation process.

Have the printer serial number ready for phone confirmation. The serial number is located on the configuration label of the printer.

1. Unlock the access door lock and open the printer access door.
2. Locate the configuration label and write down the printer's serial number.

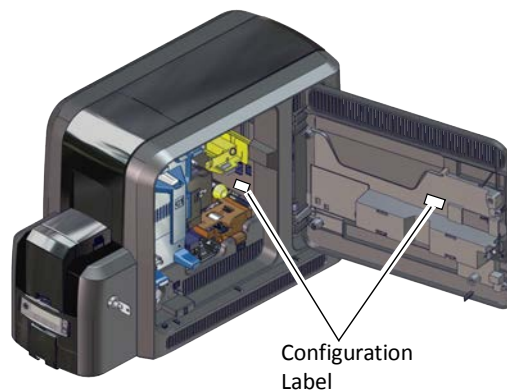

If your system includes an embosser, you also need the embosser serial number. The embosser configuration label is located inside the embosser on the lower enclosure. Open the embosser supplies access door to view the label. Refer to the printer's *User's Guide* for more information.

When the printer is deactivated, **Print job queue is deactivated** displays on the LCD panel.

1. Enter the menu system.

a. Press the USER button.

Deactivated: Menu available displays on the LCD panel.

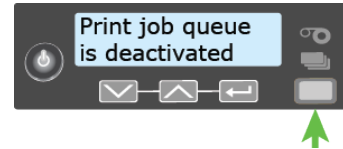

b. Press ENTER to enter the **Main Menu**.

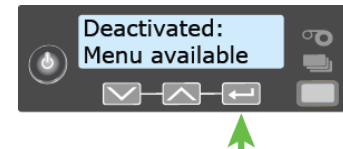

c. Press the down arrow until **Activate** displays on line 2 of the LCD panel.

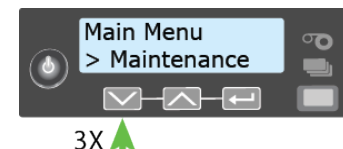

2. Enter the **Activate** menu.

a. Press ENTER to enter the **Activate** menu.

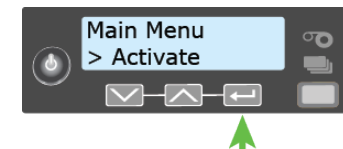

b. **Activate** displays on line 1 and **Enable** displays on line 2 of the LCD panel.

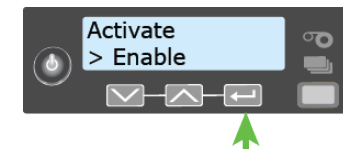

c. Press ENTER to enter the **Enable** menu.

3. Enter the activation code.

a. Press the up and down arrow keys to cycle through the numeric characters. Press ENTER to select each number that matches the 8-digit numeric activation code you received from Entrust Datacard.

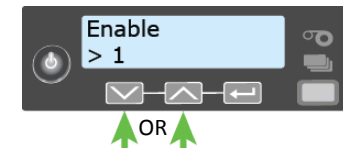

OR

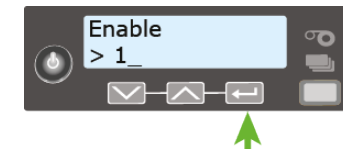

b. When the 8-digit activation code displays completely, press ENTER again with a blank character entry.

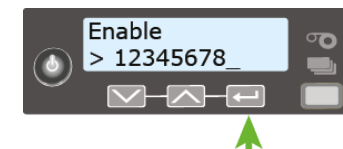

The code you entered displays on the LCD panel so you can confirm that it was entered correctly. **Apply** displays on line 2.



If the code is not correct, press the USER button to exit and return to the blank Activate screen. Enter the code again.

- c. When the code is correct, press ENTER to apply the code.

When the system activation is successful, **Request Success** displays briefly on line 2 of the LCD panel and the USER light glows steady green. The LCD panel then displays **Ready** to show that the printer has been activated.

If another message displays on line 2, system activation failed. Repeat the activation process. If activation fails again, contact Entrust Datacard technical phone support at 1-800-328-3996.

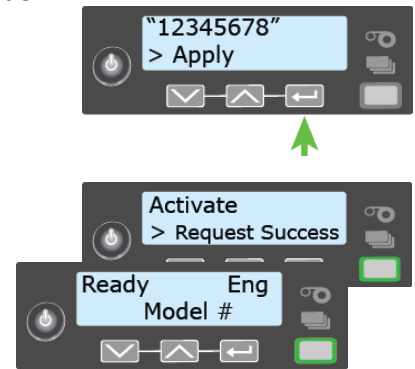

Clean the Printer

The first time you set up the printer, run an isopropanol cleaning card through the newly installed printer to remove any dust that might have collected during shipping or storage.



The printer ships with two types of cleaning cards:

- An isopropanol cleaning card, included in each ink ribbon package.
- A 10-pack of adhesive cleaning cards.

Refer to the cleaning schedule in the printer's *User's Guide* for information about when to use each type of cleaning card.

1. Open the ink ribbon container and remove the isopropanol cleaning card package.

2. Open the isopropanol cleaning card package and remove the card.

Clean the printer immediately. The cleaning card dries out if it is out of its package for more than a few minutes.

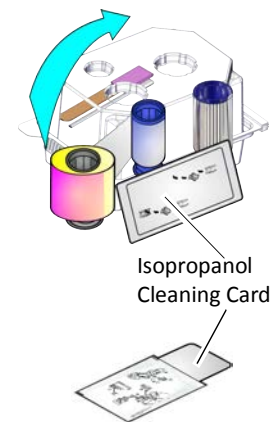

The cleaning card may become bowed slightly during shipment. If the card is bowed, insert the card into the printer as shown.

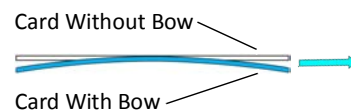

3. Continue with:
 - [Single-Hopper Printer](#)
 - [Multi-Hopper Printer](#)

Single-Hopper Printer

1. Power on the printer, if necessary.
2. Unlock the input hopper lock.
3. Open the input hopper cover.
4. Insert the cleaning card into the input hopper.
If the cleaning card appears bowed, insert it as shown.

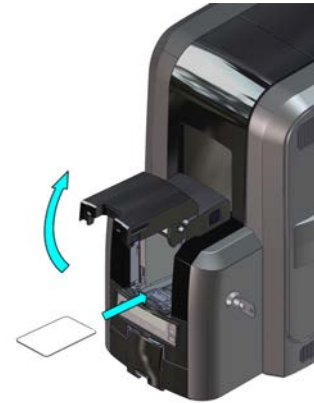
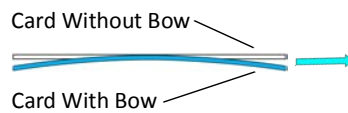

5. Close and lock the input hopper.
6. Continue with [“Start the Cleaning Cycle”](#) on [page 21](#).

Multi-Hopper Printer

1. Power on the printer, if necessary.
2. Pull out the multi-hopper exception slide and insert the cleaning card.
If the cleaning card appears bowed, insert it as shown.

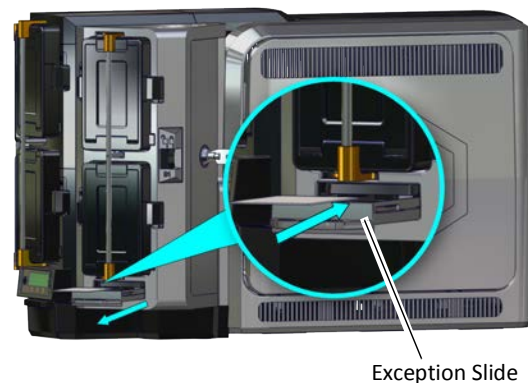
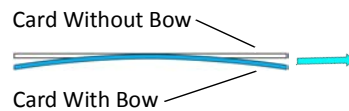

3. Push in the exception slide.
4. Continue with [“Start the Cleaning Cycle”](#) on [page 21](#)

Start the Cleaning Cycle

Use the LCD menu system to start the cleaning cycle. Begin when the printer displays **Ready** and the USER button shows steady green.

 The LCD panel may display additional prompts when cleaning a printer without locks. Follow the instructions on the panel to clean the printer.

1. Press the USER button.

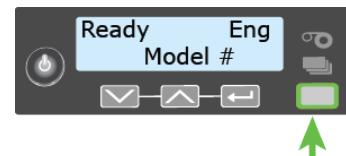

2. **Suspended** displays on line 1 of the LCD panel. Press ENTER to enter the menu system.

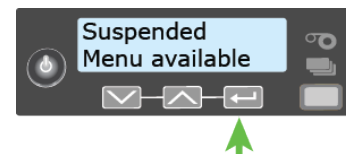

3. **Maintenance** displays on line 2 of the LCD panel. Press ENTER to enter the **Maintenance** menu.

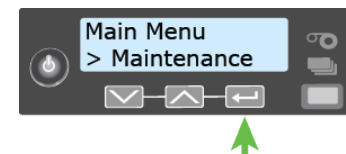

4. **Cleaning Card** displays on line 2 of the LCD panel. Press ENTER to enter the **Cleaning Card** menu.

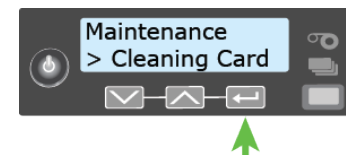

5. **Isopropanol** displays on line 2 of the LCD panel. Press ENTER to select the isopropanol cleaning card.



6. **Start** displays on line 2 of the LCD panel. Press ENTER to start the cleaning process.

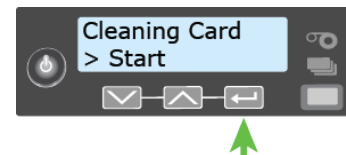

7. **Insert cleaning card** displays on the LCD panel. Press the USER button to start the cleaning cycle.

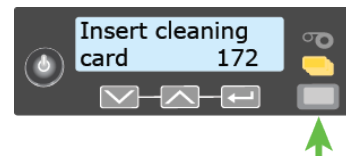

The printer moves the card through the printer several times. If the vertical option is installed, the card moves into the vertical area and cleans the rollers located there.

At the end of the cleaning cycle, the isopropanol cleaning card is ejected into the printer reject tray (RT1).



When you clean a system with an embosser, the isopropanol cleaning card moves into the embosser and cleans the card entry area and embosser rollers. The cleaning card is ejected into the embosser reject tray. Open the embosser to remove the cleaning card.

8. Open the printer access door and remove the used cleaning card.

Continue with [“Install Supplies”](#).

Install Supplies

To prepare the printer to print cards, install the ink ribbon and retransfer film on the appropriate cartridges, install a cleaning sleeve into the printer, and load blank card stock into the input hopper. The ink ribbon and retransfer cartridges are shipped inside the printer.



If your system includes an embosser, also load topping foil and indent ribbon into the embosser. Refer to [“Load Embosser Supplies”](#) on [page A-13](#) for more information.

Install the Ink Ribbon

The printer uses the ink ribbon to print the card images onto the retransfer film. Do the following to load the ink ribbon.

1. Unlock the printer, if necessary, and open the printer access door.
2. Remove the ink ribbon cartridge from the printer.
3. Place the cartridge on a flat surface with the spindles facing up.

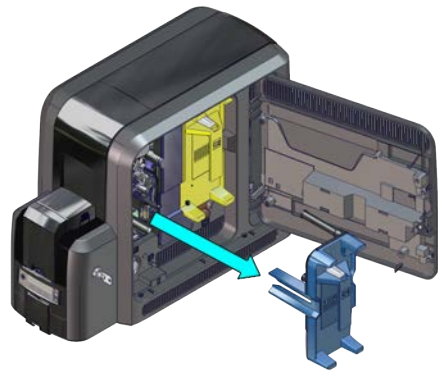

4. Open the ink ribbon package and remove the ink ribbon. Hold the ribbon cores and pull them up from the package base.

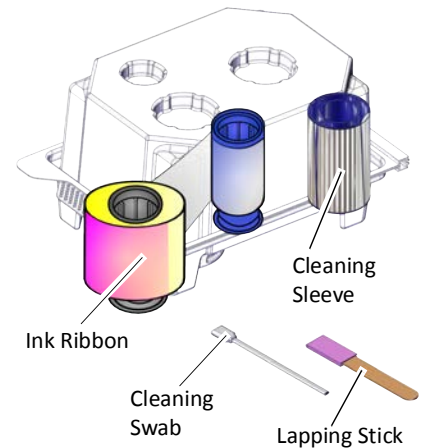

The ink ribbon package also includes the following:

- Cleaning sleeve. Refer to “[Install the Cleaning Sleeve](#)” on page 24
- Lapping stick and cleaning swab. Refer to the “Printer Cleaning Schedule” in the printer’s *User’s Guide* for complete information about when to use these items.

5. Install the ink ribbon.

- a. Slide the blue supply spool onto the cartridge until it clicks into place. The supply roll can go on only one way and fits only on the correct side of the cartridge.

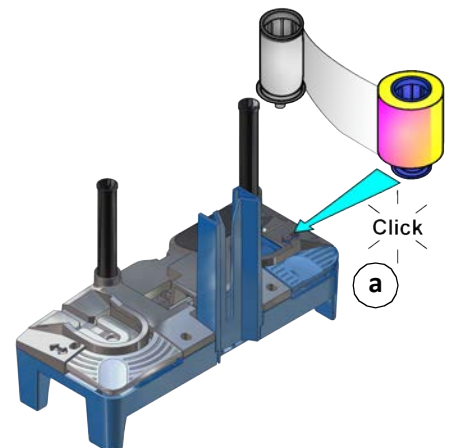

- b. Route the ink ribbon around the rollers on the cartridge. A diagram on the cartridge shows the correct routing pattern.

- c. Slide the empty silver take-up spool onto the cartridge until it clicks into place.

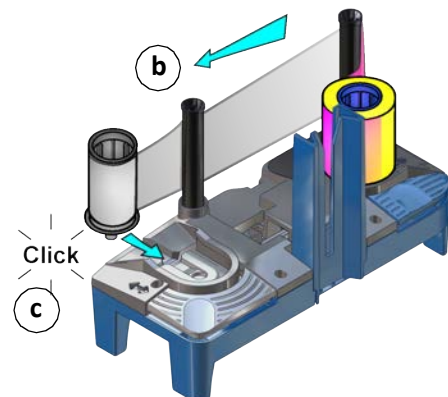

- d. Turn the take-up spool clockwise just enough to take up any slack in the ribbon.

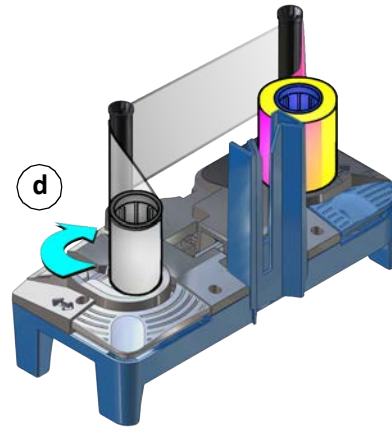

6. Continue with “Install the Cleaning Sleeve”.

Install the Cleaning Sleeve

The cleaning sleeve helps maintain print quality by removing dust and other particles from cards before they travel into the printer. The cleaning sleeve fits on a spindle that is inserted into the printer. The printer ships with the cleaning spindle in the accessories box.

-  Replace the cleaning sleeve each time you install a new ink ribbon. You also should replace the cleaning sleeve if you notice debris on the printed cards or if the cleaning sleeve is no longer sticky.

1. Load the cleaning sleeve.
 - a. Remove the cleaning spindle from the accessories box.
 - b. Remove the cleaning sleeve from the ribbon package and slide the cleaning sleeve onto the cleaning spindle.
 - c. Remove the protective wrapper from the cleaning sleeve.

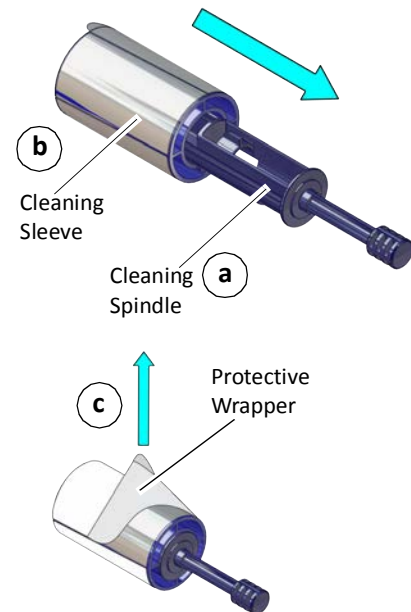

2. Insert the cleaning spindle into the C3 slot in the printer.

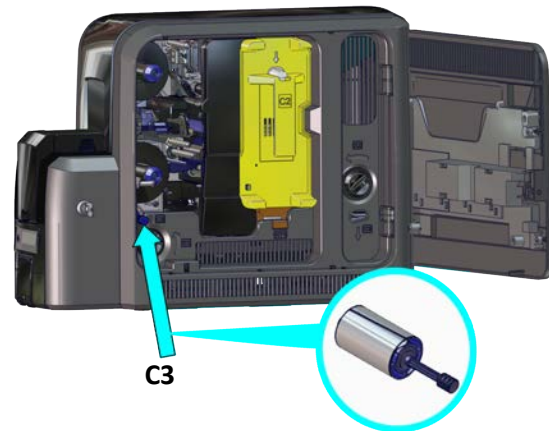

3. Replace the ink ribbon cartridge in the printer.
4. Continue with “Install the Retransfer Film”.

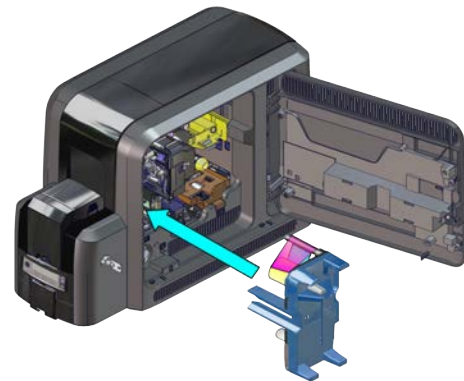

Install the Retransfer Film

The retransfer film contains the images printed with the ink ribbon. A heated roller then bonds the film onto the card. Do the following to load the retransfer film.

1. Remove the retransfer film cartridge from the printer.
2. Place the cartridge on a flat surface with the spindles facing up.

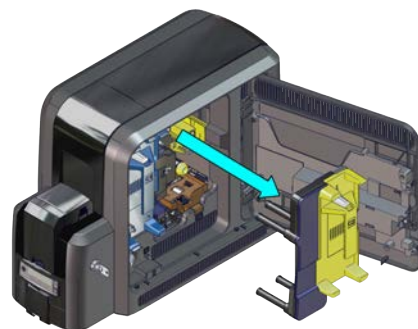

3. Remove the roll of retransfer film from its package. Hold the film cores and pull them up from the package base.

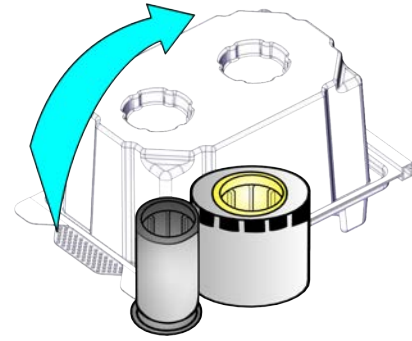

4. Install the retransfer film.

- a. Slide the yellow supply spool onto the cartridge until it clicks into place. The supply roll can go on only one way and fits only on the correct side of the cartridge.

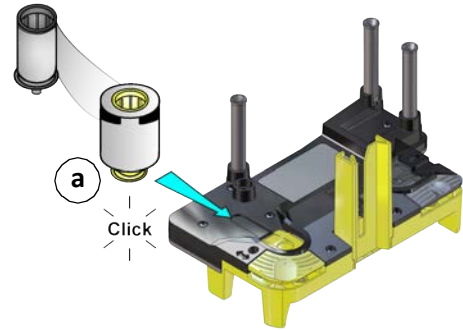

- b. Route the film around the rollers on the cartridge. A diagram on the cartridge shows the correct routing pattern.

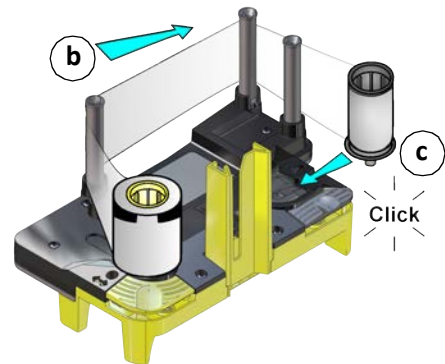

- c. Slide the empty silver take-up spool onto the cartridge until it clicks into place.

- d. Turn the take-up spool counterclockwise just enough to take up any slack in the film.

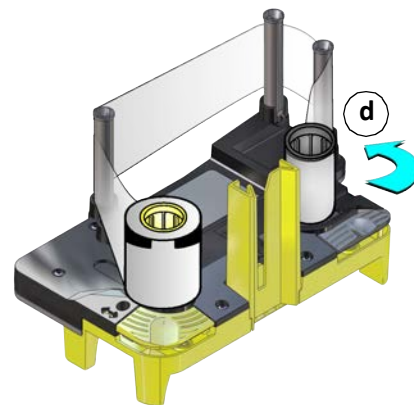

5. Replace the retransfer film cartridge in the printer.
6. Close the printer access door.
7. Continue with “Load Cards”.

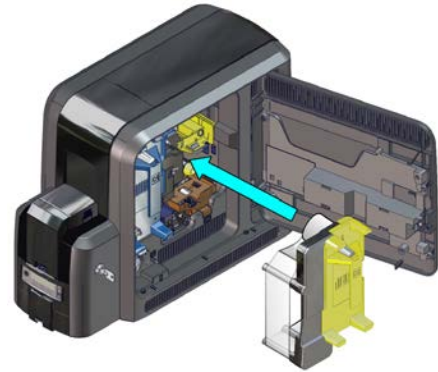

Load Cards

Do the following to load cards in the input hopper. If you plan to insert cards in the exception slot, make sure that blank cards are available near the printer.

- Handle cards by the edges only, or wear card inspection gloves approved by Entrust.
- Cards can stick together. Slide or fan the cards to separate the edges before placing them in the input hopper.
- Insert ISO magnetic stripe cards with the stripe (back side) facing down and to the right.
- Insert smart cards with the smart card chip facing up and toward the back of the hopper.



A diagram inside the input hopper shows the correct orientation for each type of card.

Refer to “Cards” on [page 114](#) for more information about card stock and card handling guidelines.

Single-Hopper Printer

1. Open the input hopper door.
2. Load the cards into the input hopper. The hopper can hold up to 125 cards.
3. Close and lock the input hopper.

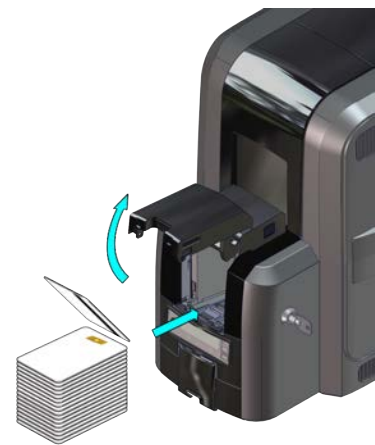

Multi-Hopper Printer

1. Unlock the multi-hopper lock.
2. Slide the lock bar release button (B1) to the left to release the hopper lock bars.
3. Rotate a lock bar to the left to provide access to the multi-hopper input cartridge that you want to load.



4. Press the cartridge release button at the top of the cartridge and open the cartridge door.
5. Lift the card weight to the top of the cartridge and gently pull it forward until it locks in position.
6. Load the cards into the input hopper cartridge. Handle the cards by the edges only, or wear card inspection gloves approved by Entrust.

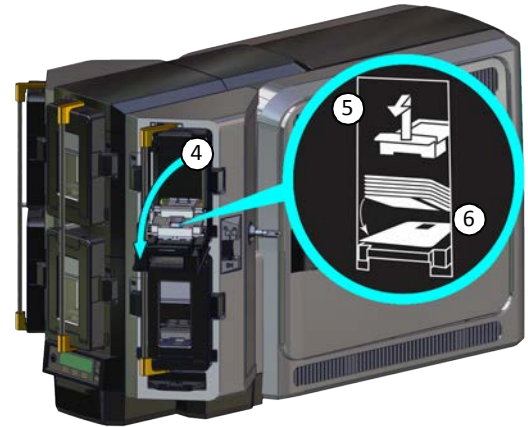

- The diagrams inside the cartridge show how to position the card weight and load cards. Do not place the cards on top of the card weight.
- You do not need to remove the cartridge from the multi-hopper to load cards.

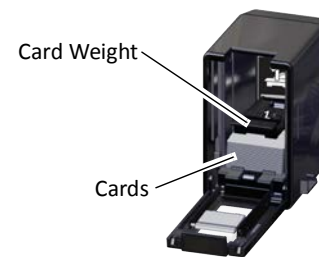

7. Close the cartridge door. This releases the card weight so that it is lowered on top of the cards.
8. Follow [step 3](#) through [step 7](#) to load cards into each input hopper cartridge.
9. Rotate all the lock bars back into position.
10. Slide the lock bar release button to the right to lock the lock bars into place.
11. Lock the multi-hopper.



Caution: The lock bars, lock bar release button, and the multi-hopper door lock all must be in the lock position for the printer to operate. If any of the locks are left in the unlock position, the printer issues an error. You must unlock and re-lock all locks to clear the error and place the printer in **Ready** status.

Install a Large Output Hopper

You can install an large output hopper on the printer, depending on your requirements.

The standard output hopper included with the printer holds approximately 25 0.030 in. (0.762 mm) cards. The printer also can be used with an optional large output hopper that holds up to 125 cards. The large output hopper consists of a 125-card replacement hopper and an extended pedestal base.

-  • The large output hopper can be installed only on single-hopper CR825 systems.
- The large output hopper cannot be installed on the CE875 instant issuance system.

Do the following to install the large output hopper.

1. Remove the standard output hopper from the printer.

Pull the hopper straight out from the printer.



2. Place the printer on the extended pedestal base.
Make sure that it is lined up correctly on the pedestal.



3. Insert the 125-card output hopper into the printer and pedestal until it clicks into place.
4. Follow the instructions included in the upgrade kit to complete the installation.



Connect to the Printer

You can connect to the printer from a Windows-based PC through a network (an Ethernet cable is not supplied with the system).

1. Connect one end of the Ethernet cable to the network connection port on the printer.
2. Connect the other end to a network port.
3. Refer to “[Set a Static IP Address](#)” on [page 32](#) and the *Card Printers in Adaptive Issuance Instant Financial Issuance Software Setup Guide* for information about how to define the printer to Instant Financial Issuance software.

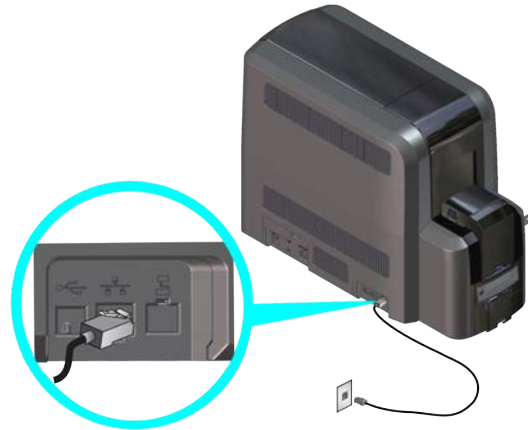

Set the Printer Network IP Address

The printer's IP address is used to access Printer Manager from a browser window. You also need the IP address to define the printer to Instant Financial Issuance software.

To display the network IP address, you can do one of the following:

- Press the up or down arrow key on the front panel while the printer displays **Ready**.
- Use the LCD menu system Status menu. Refer to the printer's *User's Guide* for more information about using the Status menu to display the IP address.

The printer can use either of the following network communication methods:

- **DHCP (Dynamic Host Configuration Protocol)**—The network automatically assigns the IP address to the printer. The IP address of a printer that uses DHCP can change if the printer is powered off and back on.
- **Static IP**—You set the IP address, subnet mask, and gateway address, as provided by your network support personnel. A static IP address does not change when the printer is powered off.

Instant Financial Issuance software requires that the printer use a static IP address. Refer to ["Set a Static IP Address"](#).

Set a Static IP Address

Instant Financial Issuance software requires that the printer have the same IP address at all times. Because the default communication method is DHCP (Dynamic Host Configuration Protocol), you must change the address method and assign a static IP address before you can define the printer to Instant Financial Issuance software.



- You can set a static IP address on a printer even if it is not connected to the network. For example, a group may set up several printers in a central location before installing them at individual sites.
 - When the printer is configured to use a static IP address, the printer's front panel displays the address even when the printer is not connected to a network. In addition, the LCD displays a "+" if the network is active, or a "-" if the network is inactive, as a prefix to the static IP address.
1. Obtain the following values from your network support personnel. Make sure you receive all three values:
 - IP address
 - Subnet mask
 - Gateway address
 2. Enter the menu system.

- a. Press the USER button to suspend the printer.
 - b. Press ENTER to enter the menu system.
 - c. Press the down arrow until **Configuration** displays on line 2.
 - d. Press ENTER to enter the **Configuration** menu.
 - e. Press ENTER to enter the Network IPv4 menu. **DHCP/Static IP** displays on line 2.
 - f. Press ENTER to select an address method.
 - g. Press the up or down arrow to display **Static IP** on line 2.
 - h. Press ENTER to enter the **Static IP** menu.
3. Set the static IP address, subnet mask, and gateway address.
 - a. Press ENTER with **IP Address** on line 2 to set the static IP address.

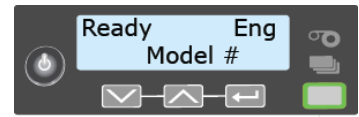

2X ↑

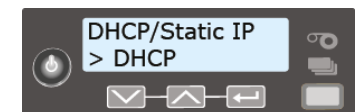
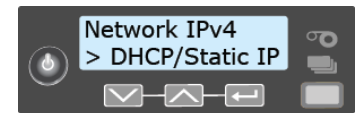
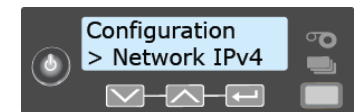
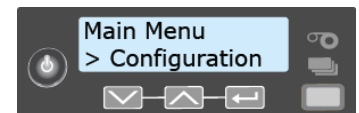

↑ OR ↑

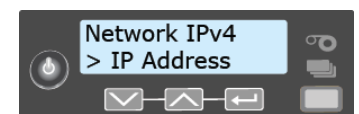
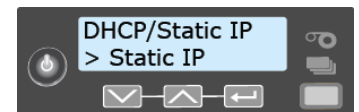

The IP address has four sections, separated by periods. A cursor appears under the digit that will change.

- i. The address section shows three digits when it can be changed and the cursor is under the right-most digit. Use the arrow keys to change one digit at a time. Press ENTER to navigate to the next section of the address.



OR



- ii. When all four sections are correct, press ENTER. The next section of the address entry (**Subnet Mask** or **Gateway Address**) displays on line 2 of the LCD panel.



- b. Repeat step a, i through ii, to enter the subnet mask and gateway address.

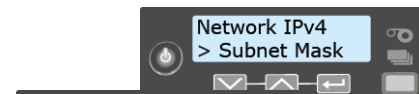

4. Press ENTER when you finish entering all the required address information. **Apply** displays on line 2.
5. Press ENTER to apply your changes.
6. Press the down arrow key until **Exit** displays on line 2.
7. Press ENTER. Then, press the USER button to return the printer to **Ready**. The USER button glows green.
8. Press the POWER button to power off the printer. Restart the printer and verify that the static IP address is correct.

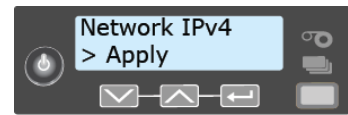

Test the IP Address Using a Local Network

You can set up a local network consisting of the printer and a computer. This allows you to test whether the printer and computer can communicate using the static IP address, and to test that the printer is functioning correctly. You might use this procedure if you set up multiple printers in a central location before installing them at individual sites.

 This procedure is optional.

1. Connect the printer directly to a computer using an Ethernet cable.
2. Open the Windows Network and Sharing Center and select **Local Area Connection**.
3. Click **Properties** on the Local Area Connection Status menu.

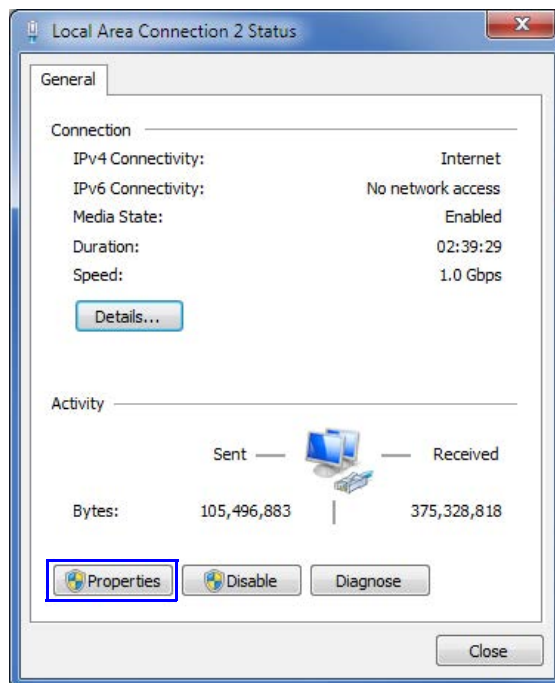

4. On the Local Area Connection Properties dialog box, select **Internet Protocol Version 4 (TCP/IPv4)**. Click **Properties**.

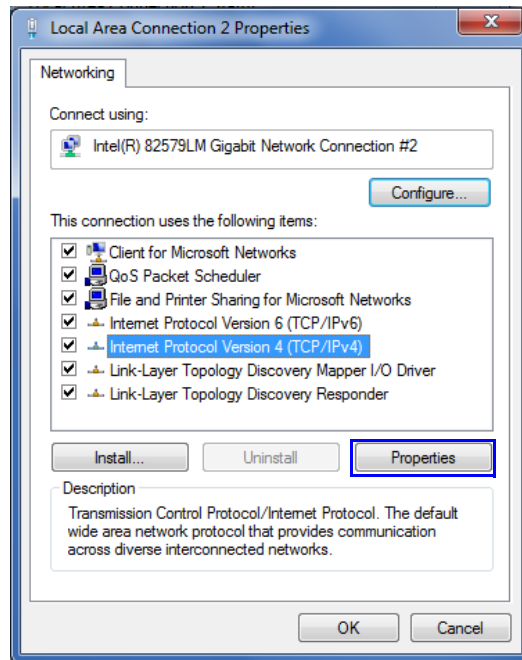

5. Use the Properties dialog box to enter the IP address information. Select **Use the following IP address**.

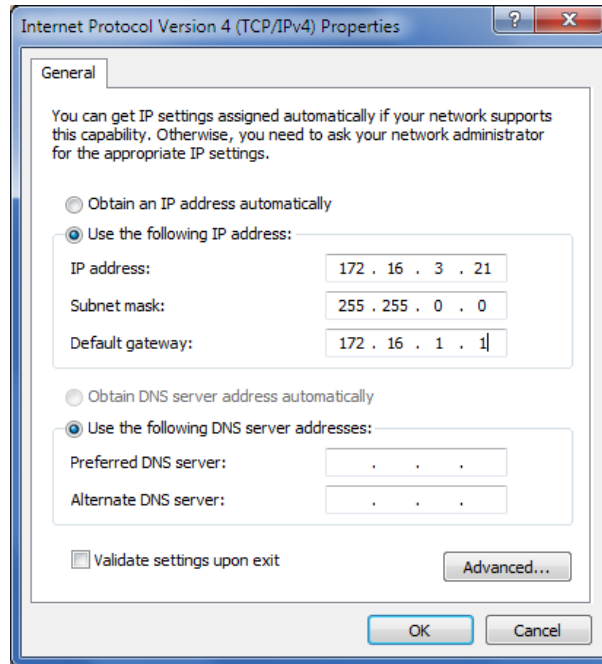

- a. In the IP address field, enter the value for the static IP address that you set on the front panel of the printer. Give the last section of the IP address a value that is at least plus one from the address on the printer front panel.



For example, if the IP address that is set on the front panel of the printer is 172.17.1.113, enter the address as 172.17.1.114 on the computer.

- b. In the Subnet mask and Default gateway fields, enter the subnet mask and default gateway address that you entered on the front panel of the printer.
 - c. When you finish entering values for IP address, subnet mask, and gateway address, click **OK**.
6. Test the printer to verify that it can communicate with the computer using the IP address. Run several test cards to make sure that the printer is functioning properly. Refer to [“Print a Test Card”](#).
 7. Power off the printer and disconnect it from the computer.
 8. Connect the printer to the network and power it on.
 9. Log in to Printer Manager and configure the printer based on your requirements. Refer to [Chapter 3: “Printer Manager”](#) for complete information about using Printer Manager.

Print a Test Card

The printer includes a test card that prints without using a driver or other source of card data. Use it to verify that the printer is printing correctly. Make sure that cards are in the input hopper and all supplies are loaded before you begin. Refer to “Install Supplies” on page 22 for complete information.

1. Begin with the printer **Ready**. The USER button shows steady green.
2. Press the USER button to display **Suspended** on line 1 of the LCD panel.
3. Press ENTER to enter the menu system.

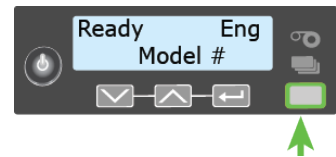

4. Press ENTER to enter the Maintenance menu.

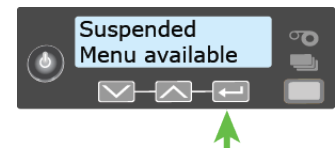

5. Press the down arrow until **Test Card** displays on line 2.

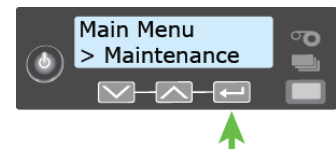

6. With **Test Card** displayed on line 2, press ENTER to display **Start** on line 2.

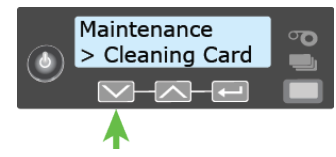

7. Press ENTER to print the test card.

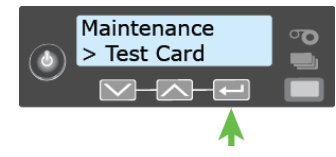

After the card prints, the printer returns to **Ready**.

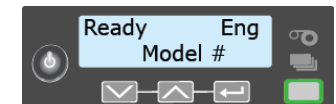
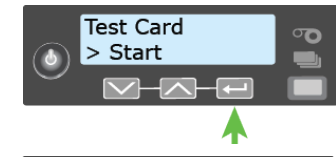

Set Up Network Access

Work with your network support personnel to make sure that the printer is set up within your organization.

You may need to perform the following tasks:

- Know the IP address of the printer.
- Set up network security.
- Define network permissions to the printer and to Instant Financial Issuance software.
- Define the printer to Instant Financial Issuance Administrator. Refer to the *Card Printers in Adaptive Issuance Instant Financial Issuance Software Setup Guide* for more information.

Your organization is responsible for network setup and security.

Verify Network Communication

Access Printer Manager to verify that your computer and the printer can communicate over the network. You also can use Printer Manager to perform other printer setup tasks, as necessary.

Refer to [Chapter 3: "Printer Manager"](#) for complete information about using Printer Manager.



Chapter 2: Elements of Card Design

2

Card design is the name given to the combined features of the processed cards. An organization can have multiple card designs.

This chapter provides the following information about card design:

- [Basic Card Design](#)
- [Printing Design on page 42](#)
- [Magnetic Stripe Design on page 52](#)
- [Smart Card Processing on page 54](#)
- [Embossing and Indenting Design on page 56](#)
- [Settings for Card Design in Printer Manager on page 56](#)

Basic Card Design

Card design includes:

- Color and monochrome printing.
- The various types of data, such as name, account number, emboss and indent information, and special features such as a magnetic stripe, signature panel, and smart card chip.
- The layout of the data.
- Processes to enhance card appearance such as adding embossing or indent characters.

Card Back

Magnetic Stripe
Signature Panel
Indent Characters

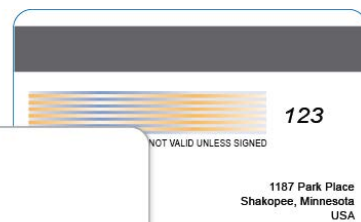
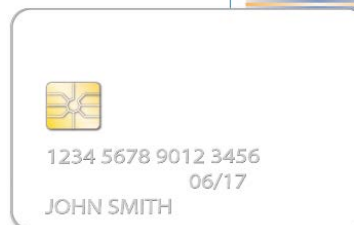

Card Front

Smart Card Chip
Emboss Characters
Account Number

Printing Design

Printing design includes color and monochrome printing, bar code printing, non-printing areas, and card layout.

Color Printing

The retransfer printing process uses two types of supply: a color pigment ink ribbon and a retransfer film. The color ink ribbon typically contains the following panels, C (cyan), M (magenta), Y (yellow), K (black), and P (primer). Other ribbon types also may have an inhibitor (I) panel.

CMYKP Ribbon



The printer prints separate layers of cyan, magenta, yellow, black, and primer on a transparent retransfer material. Heat from the printhead causes the ink pigment to release from the ribbon and adhere to the retransfer material. The printed images are then transferred to the card using a heated roller.

The layers are applied to the card in the reverse order that they were applied to the retransfer film. The primer, which is applied last to the retransfer film, is applied first to the card and allows the image layers to bond to the card surface. The retransfer film consists of a carrier material and a film coating. The coating is applied last to the card and acts as a protective layer for the printing. You can select to apply a second layer of the retransfer film coating for added durability.

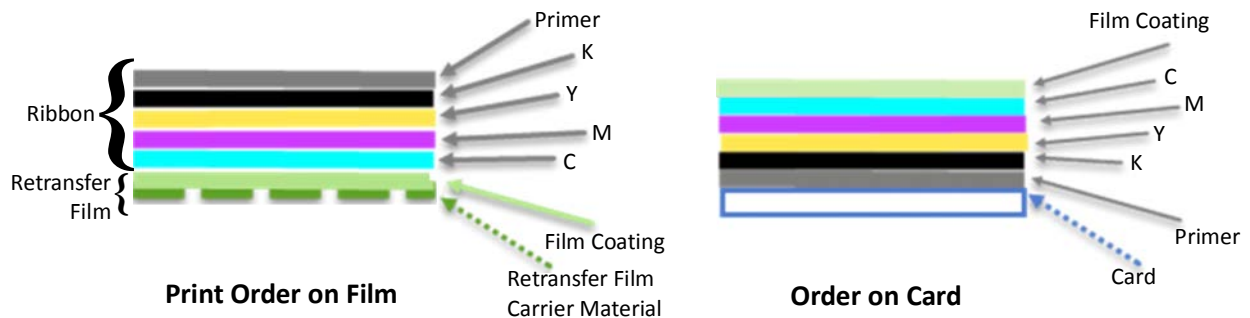

Ink ribbons also may include an I (inhibitor) panel that prevents any ink or retransfer material from bonding to areas of the card that have a magnetic stripe or signature panel.

CMYKP-KPi Ribbon



The inhibitor is used only to prevent printing on the magnetic stripe and signature panel. It is available only on the back side panel set.

Color Management

The printer uses color modes that are calibrated and installed in the printer during manufacturing. You can select the color mode that best meets your card printing requirements. Refer to “Print” on [page 81](#) for more information.

Print Text in Color

The printer can print text in any color. It prints at a resolution of 600 x 600 dpi and can support type sizes down to 2-point text. Small characters are likely to be more readable if you use a sans-serif font formatted as black and printed with the black (K) panel. Refer to “Print Text in Monochrome” on [page 44](#).

Print Graphics in Color

The printer produces full-color images from most types of graphics. It can use BMP, JPEG, TIFF, and PNG file formats for photos and logos.

Vector graphics, such as WMF and SVG files, have components such as shapes with lines and fills. Components defined as black normally print with the K panel.

Because the printer is pigment-based, the black panel is used to darken other colors, in addition to printing any black elements. The black ink is beneath the color (YMC) pigments when they are placed on the card. Your card personalization software handles sending the card elements so they print correctly on the card.

Types of Color Images

Cards can include both color photos and color logos. The logo is usually the same on each card, and the photo is unique. Follow these guidelines to obtain the best results for printing both logos and photos.

1. Evaluate the color quality of the photos:
 - a. Adjust the image capture system to get the best quality photos; work with distance, lighting, and camera settings to obtain consistent, high-quality photos.
 - b. Evaluate the quality of printed photos after the image capture system is optimized.
2. Evaluate the other color areas of the card, such as text or logo:
 - a. Check your card production application for settings that can help improve the printed color of text.
 - b. Use an image editing application to adjust the color of a logo file for optimal printing.

Monochrome Printing

Monochrome printing prints cards using a single color. You can use the black panel of a full-color ribbon to print monochrome elements.

Monochrome Printing with Full-Color Ribbon

Full-color ink ribbon includes a black panel. Text and bar codes are usually printed with the black panel. Full-color print ribbon also prints any monochrome or one-bit-per-pixel graphics using the K panel.



Print Text in Monochrome

Printing text using a K panel can make text look crisp, because it uses only one panel for printing.

The font used also affects legibility. The printer reliably prints 2-point Arial font. Bold, sans-serif fonts are more readable after printing than serif fonts, or fonts with thin strokes, as shown at right. In the example, fonts that print well are shown toward the top of the card.

AaBbMmYy0123456789	8 pt Arial Bold
AaBbMmYy0123456789	8 pt Arial
AaBbMmYy0123456789	6 pt Arial Bold
AaBbMmYy0123456789	6 pt Arial
AaBbMmYy0123456789	4 pt Arial Bold
AaBbMmYy0123456789	4 pt Arial
AaBbMmYy0123456789	8 pt Times New Roman
AaBbMmYy0123456789	8 pt Courier
記號号日月12345	8 pt MS Mincho

Print Bar Codes

Bar code design follows a set of standards based on the type of bar code produced. Bar codes contain a series of black lines (bars) separated by white areas (spaces). Each character of encoded data is represented by a set of bars and spaces. A bar code standard specifies the number and width of bars and spaces needed to encode a character. The standard also specifies the minimum size of the white area, or quiet zone, that surrounds the bar code.

Bar Code Guidelines

Bar codes print more successfully when you observe the following guidelines. Follow the standards for the type of bar code you are printing.

Bar Code Placement

- Maintain the required quiet zone around the actual bar code, as shown in the illustration.
- Locate bar codes at least 0.25 inch (6.3 mm) from other printing and from the edge of the card.

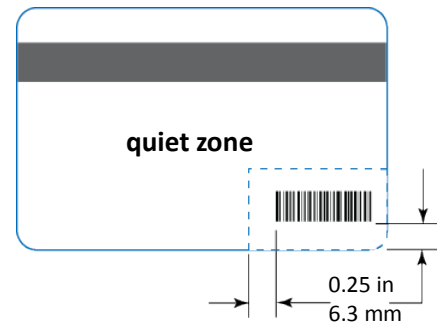

Bar Code Size

- A lower density bar code is easier to read, because the bars are wider and spaced farther apart.
- The width of the narrow elements in the bar code must be large enough to be read consistently. The capabilities of the bar code reader can influence this.
- The bar code must be tall enough to be read under normal conditions.

Bar Code Print Settings

- To achieve the best quality printing and improve the readability of the bar code, use the K (black) panel of the color ink ribbon to print the black bars. Bar codes printed with the color panels may not be as crisp and sharp as those printed with the K panel only. Refer to the documentation for your card personalization software for more information about how to print bar codes using the K panel.
- Infrared readers require that the K panel be used to print the bar code.

Test Bar Codes

Always test the readability of bar codes under production conditions. Factors to consider include:

- If you print cards one at a time, print the samples using that method. If you print cards in batch (many cards sent to the printer at the same time), use a production-sized batch and evaluate cards from the beginning, middle, and end of the batch.
- Use exactly the same card stock for testing that you use for production. The card stock can affect the readability of bar codes. Usually, a white surface that reflects light in many directions is needed. Test cards before purchasing production quantities.
- Include other card design components that you use in production.
- Use the same bar code readers that users have, and test each card multiple times. Also test multiple cards.

Card Design Changes That Affect Bar Codes

If you make substantial changes to the way you produce cards, review your setup tasks to make sure that cards continue to have the quality you require.

The following production changes can change the color of some images and can affect bar codes:

- Purchasing a new brand of card stock
- Changing to, or from, preprinted cards

If you change the design of your cards, or if you start producing an additional card design, test each design as described in [“Test Bar Codes”](#) to make sure that the bar code prints as expected.

Apply a Second Layer of Retransfer Film

The printer can apply two layers of retransfer film to the front side or both sides of the card. The second layer of retransfer film does not have any printing on it, but it provides added durability for the card.

The second retransfer film layer must be requested by Instant Financial Issuance software when it sends the card to the printer. Refer to your Instant Financial Issuance documentation for more information.



You cannot apply retransfer film over the magnetic stripe or signature panel on the back side of the card. Do not request a second layer of retransfer film on both sides if your card has a magnetic stripe or signature panel on the card back. Because the inhibitor panel is not used, the second layer of film will be applied over those features and make them unusable.

Non-Printing Areas

The card design can have areas where printing or retransfer film cannot be placed, such as a magnetic stripe, signature panel, or smart card chip. The inhibitor panel of the ink ribbon prevents the retransfer film from bonding to the magnetic stripe and signature panel. You must block the application of printing and primer over the smart card chip using design elements in your card production software.

Instant Financial Issuance software usually manages standard non-printing areas automatically. If necessary, you can use the measurements provided in the following sections to customize your non-printing areas.



The dimensions shown are examples to help you determine the non-printing area. The actual dimensions can vary depending on the card stock you use.

Print several cards using your card design and application to verify that the card is printing as you intend.



When you specify the non-printing area over a feature, the retransfer film must overlap all edges of the feature by 0.5 mm. This makes the actual non-printing area smaller than the feature. The dotted lines in the diagrams in the following sections show the retransfer film overlap onto the magnetic stripe or smart card chip.

Standard Magnetic Stripe Non-Printing Area

The magnetic stripe typically is located on the back of the card.

The following table shows the standard measurements for magnetic stripes. Use these values if you need to define a non-printing area. The retransfer film must overlap the magnetic stripe by 0.5 mm (indicated by the dotted lines).

	A	B	C
3-track	5.0 mm	13.5 mm	86 mm
2-track	6 mm	9 mm	86 mm
Single-track (JIS)	7.5 mm	7.5 mm	86 mm

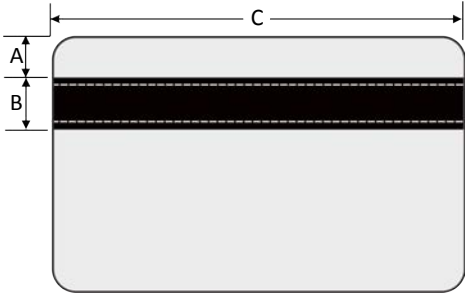

Standard Smart Card Non-Printing Area

The smart card area typically is located on the front of the card.

The following table shows the measurements for a typical smart card chip. The smart card chip can vary in size, shape, and location. Adjust these values based on the card stock you use. The retransfer film must overlap the smart card chip by 0.5 mm (indicated by the dotted lines).

A	B	C	D
19.5 mm	10 mm	13 mm	12 mm

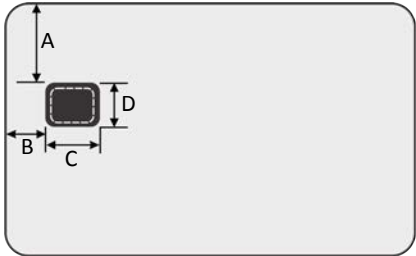

Custom Non-Printing Areas

Instant Financial Issuance allows you to define an additional non-printing area, such as a signature panel.

 We recommend that you do not define non-printing areas over other parts of the card. The retransfer film will be placed over these areas even if no printing is present.

Card Layout

The arrangement or layout of components determines how well your card design works for users. Use the following guidelines when creating a card design.

Image Size

The image that is sent to the printer is larger than the card size. The printer adjusts the image to fit the card, which allows the printer to print up to the edge of the card with no unprinted margins.

	Size (pixels)	Description
Image	2100 x 1344	The size of the 600 dpi image that is sent to the printer.
Film Canvas	2059 x 1312	The size of the non-masked portion of the image after the printer masks off the edges.
Image Size on Card	2023 x 1276	The portion of the film canvas image that prints on the card. Note: The image origin on the card can vary, depending on the software application used to send the print job.

The following illustration shows the image that is sent to the printer:



Image Sent to the Printer
2100 x 1344 pixels

The printer then masks the edges of the image and prints the image on the card. The image prints to the edge of the card with no unprinted margins.

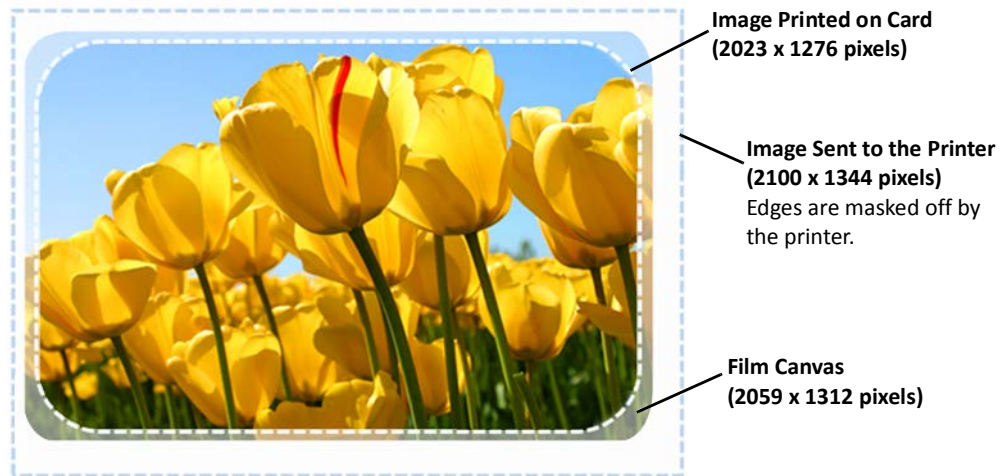

Image Printed on Card After Processing by the Printer

Backgrounds

Use the following suggestions to help you select a background for a professional-looking card.

- Use colors and images that do not make it difficult to read the text on the card.
- Use 600 dpi images that are sized to match the image canvas.

Image Placement

Use the following suggestions to help you place important images, such as a photo, logo, or bar code. When placing images, avoid areas of high wear.

- Do not place an important image on the front of the card in the same area as a magnetic stripe or other machine-readable feature. Frequent use of a card in a reader can wear away the image on the opposite side of the card.
- Do not place an important image directly on the opposite side of a smart card chip.

Magnetic Stripe Design

The printer’s magnetic stripe module allows the printer to process magnetic stripe data. There are two magnetic stripe configuration options: ISO and JIS. Use the printer configuration labels (described in the printer’s *User’s Guide*) to determine the type of module installed.

Magnetic Stripe Data Formats

The module format (ISO or JIS) defines the type and format of the information to encode. The standard ISO format (also known as IAT) is a three-track option. The JIS format is a single-track option. Both formats include default data settings that determine how many characters can be encoded on each track, and which characters can be encoded.

Your cards can use the default format for each track, or can use a different combination of tracks and data formats.



Three-Track Option (ISO/IAT)

The default data formats for a three-track magnetic stripe option are:

- Track 1 — IATA
- Track 2 — ABA
- Track 3 — TTS

This combination is often abbreviated IAT. This format is also called ISO format.

IATA (International Air Transport Association)

The maximum number of characters for IATA format data is 76 characters. These characters can include spaces, uppercase alphabetic characters (A–Z), numeric characters (0–9), and the following special characters:

! # \$ % ' () * + , - . / ; : < @ > = ^] \ [" & _

ABA (American Bankers Association)

The maximum number of characters for ABA format is 37 characters. Numeric characters (0–9) and the following special characters are allowed:

: ; < = >

TTS (Thrift Third Standard)

The maximum number of characters for TTS format is 104 characters. Numeric characters (0–9) and the following special characters are allowed:

: ; < = >

Single-Track Option (JIS)

The default data format for a single-track magnetic stripe module is the JIS (Japanese Industrial Standard) Type II format.

The maximum number of characters for the JIS format is 69 characters. These characters can include spaces, numeric characters (0–9), uppercase alphabetic characters (A–Z), lowercase alphabetic characters (a–z), and the following special characters:

!"#\$%&'()*+,-./:;<=>?@[]^_`{|}~

A PC running a Japanese edition of a supported Windows operating system also supports Japanese-language special characters and 55 Katakana characters. They include the following:

- Special characters:

。 『 』 、 ・ ー 々 。

- 45 Katakana characters:

アイウエオ
カキクケコ
サシスセソ
タチツテト
ナニヌネノ
ハヒフヘホ
マミムメモ
ヤ ュ ヨ
ラリルレロ
ワ ン

- 10 Katakana characters:

フ アイウエオヤユヨツ



The magnetic stripe data uses shift-JIS, which embeds a hidden "shift-in" and "shift-out" character each time the Japanese-language characters start and end. Each transition between normal characters and shifted characters is surrounded by these two control characters. They are encoded on the magnetic stripe. Thus, each hidden character reduces the number of characters you can encode by one character.

Magnetic Stripe Coercivity

The printer may require additional settings to match the coercivity of the card. When these values are set they remain the same for all cards processed using the same design. The defaults are set to standard ISO format and high coercivity. Refer to “[MagStripeGeneral](#)” on [page 93](#) for information about changing the coercivity.

The type of magnetic stripe cards you use must match the type of module installed. Test your system to make sure that the printer is encoding magnetic stripe information properly.

Smart Card Processing

Smart card processing differs from other types of card personalization. The “smart card” step of personalization is controlled by an application that is separate from the rest of card personalization.

The smart card reader can be factory-installed, or installed later as a field upgrade by a service provider or value-added reseller. The printer configuration label (or a label attached at the time of the field upgrade) shows the type of smart card reader installed. You can request additional information about the smart card reader and the type of cards to use from your service provider or value-added reseller.

Smart Card Processing Requirements

The following items are required to personalize smart cards:

- A smart card reader in the printer
- A card production application that is designed to work with the printer and the smart card application
- Smart cards that work with the reader installed in the printer

Smart Card Codes on the Printer Labels

The configuration labels include codes that identify the type and model of the smart card reader installed in the printer. The following table lists the codes used on the configuration labels.

Code on Label	Type of Smart Card Module
S1	Integrator Contactless
S5	iCLASS Read/Write Contactless
S11	Identive
S12	pcProx Plus Dual Frequency
S13	DUALi Single Wire
S14	OMNIKEY
S16	OMNIKEY Single Wire

The S1 value on the configuration label indicates that the printer has the basic smart card components installed. Basic components include the mounting hardware only. An integrator must install a contactless reader.

If the Sx value is included in the configuration code, the printer has the basic components of an S1, plus the appropriate interface installed.



The smart card readers available may vary by printer model. Contact your authorized dealer for more information.

Single-Wire Smart Card

Single-wire smart card processing allows a single USB or Ethernet connection with the printer to carry data for both smart card personalization and printing.

The single-wire smart card feature is available through your card personalization software.



The single-wire smart card programming interface is similar, but not identical, to the PC/SC standard. Applications using PC/SC to personalize smart cards may require modification to use the single-wire smart card interface.

Embossing and Indenting Design

The CEM Embosser is the component of a card production system that creates the raised lettering and numbering on the front of most financial or debit cards. Inside the embosser, you find the embossing wheel and topping and indent ribbon cartridges. The embossing wheel can be purchased with up to 75 punch and die or punch and anvil (indent) pairs. A second wheel option allows for up to 75 additional punch and die characters (indent is not available on the second wheel). Features of the embossing wheel that are determined at time of purchase include multiple font choices and a variety of special characters.



The embossing wheel with indent characters allows you to produce characters that are pressed into (indented) the front or back surface of the card. The most common use of indent characters is to create the Bank Identification Number (BIN) and Card Security Code (CSC), sometimes called the Card Verification Value (CVV), on financial credit and debit cards. Indent ribbon is available in black or white.

The embosser can emboss up to five lines of text or numbers. Topping foil is then heat sealed to the embossed characters. The foil is available in six colors.

Refer to [Appendix A: "CE875 Instant Issuance System"](#) for more information about setting up an embossing system.

Settings for Card Design in Printer Manager

Printer Manager contains card design settings that administrators and service providers can use to set up card production. The card design settings include magnetic stripe setup and smart card testing. Printer Manager also contains troubleshooting features such as a log file that can track all processes of a card job. Service providers can use the information in the log file to troubleshoot and relay information when troubleshooting card processing issues. Refer to [Chapter 3: "Printer Manager"](#) for more information.



Chapter 3: Printer Manager

3

This section describes Printer Manager, the Entrust web interface available to users, administrators, and Entrust service providers.

Printer Manager

Printer Manager is a web-based interface that displays information about the printer. System administrators and service providers can use Printer Manager to fine-tune card appearance, set advanced options, and troubleshoot printing problems. You can access Printer Manager using an Internet browser and the IP address of the printer.

Printer Manager includes different user access levels that control the type of information that can be viewed. You can choose from three user access levels to perform a variety of basic and advanced tasks: WebUser, WebAdmin, and WebService.

Printer Manager User Access Levels

The **Username** field controls the level of access to information and settings that correspond to the user's job responsibility.

WebUser

WebUser access allows users to view information and change a limited number of values. The WebUser access level typically is used by the person responsible for printing cards. Other responsibilities can include cleaning the printer, ordering printer supplies, or printing a daily or weekly log of card production.

The WebUser access level displays four menu selections: Status, Printer Setting, Maintenance, and Log Out.

WebAdmin

WebAdmin access allows an administrator to make minor adjustments to the printer. The WebAdmin user has access to configuration options and the use of diagnostics tools for troubleshooting. The WebAdmin user also can specify a password (using the **Printer Settings > Update Password** option) for WebUser access-level users.

In a card production environment, the WebAdmin access-level user typically sets up the card design, verifies communication with external data sources, and tracks printer activity and performance.

WebService

WebService access has all of the above adjustments with additional access to test and adjust motors, sensors, and other internal components.

The WebService user typically is an Entrust-trained service provider.

Access Printer Manager

The initial Printer Manager screen allows users to log on with a user name and password that determine their user access level. The user access level determines which menu items, options, and adjustments are available.

1. Make sure that the printer's LCD panel displays **Ready**.
2. Do the following to access Printer Manager:
 - a. Obtain the printer network IP address and write it down. Refer to the printer's *User's Guide* for detailed information about how to retrieve the printer IP address.
 - b. Open a web browser on the PC and enter the IP address using the following format:
https://xxx.xxx.xxx.xxx

For example: https://123.12.3.123



- When you use a secure protocol (https), the browser may display a warning message indicating a problem with the website's security certificate. Continue to the website to access Printer Manager.
- **Windows 10 Users:** If the "site not secure" window displays, click **Details** to expand the window, and then click **Go on to the webpage**.

3. When the Printer Manager Log In screen displays, select the language in which to display the Printer Manager session from the Select Language column.

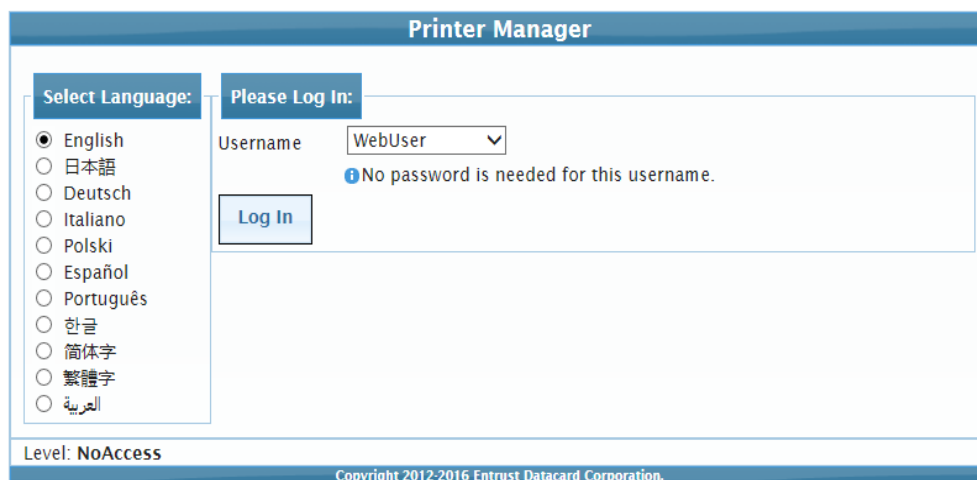

4. In the **Please Log In** section, select a Username that matches your job responsibility and enter a password (if required). Refer to "[Printer Manager User Access Levels](#)" on [page 60](#) for a description of the user access levels.

5. Click **Log In** to display the Printer Manager Welcome page.

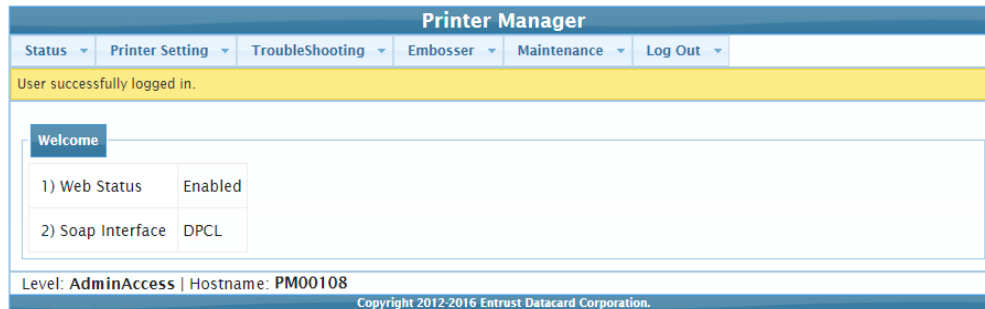

HINTS & TIPS

- If the browser cannot connect to the printer, make sure that **Ready** displays on the LCD panel of the printer.
- Some Printer Manager pages feature hover text that displays help information when the cursor hovers over the setting in the description column.

Printer Manager Settings

The printer is shipped with recommended settings in Printer Manager. You may need to change these settings to customize the printer for your site. Printer Manager provides access to the printer settings.

Many of the Printer Manager menu options display the **Set Current** button. **Set Current** saves any changed settings on the displayed page. When you change a value and click **Set Current**, the printer uses the new settings. If you exit a page without clicking Set Current, your changes are not applied.



If you enter a value outside the allowed range for a setting, the settings are not updated and a message displays asking you to correct your entry.

If you enable or disable a feature in Printer Manager, restart the printer for the new setting to take effect.

Print a Printer Manager Page

Use your Internet browser Print option to print the information from any Printer Manager page to a paper printer.

- Select **File > Print** from your Internet browser's main menu.
- If the printed page does not display all the information from the Printer Manager, select **File > Print Preview** in your Internet browser to scale the image to fit the paper.

Use Printer Manager

The following sections describe how to use the options on the Printer Manager menus that are available to WebUser and WebAdmin access-level users. For information about settings available to the WebService access level, contact your service provider.



The options available in Printer Manager are determined by the printer model and the options installed on the printer. The Printer Manager options described in the following sections may not be available for all printers.

Status Menu

The **Status** menu displays general information about the printer and its usage statistics. Users at all access levels can view or print the Status menu information. You cannot change the information on the Status menu.



Status Menu Option	Function	WebUser	WebAdmin
VPD	Display printer vital product data (VPD), including the manufacturer, model, installed options, serial numbers, and version numbers. Print this page for reference if you need to contact your service provider.	View	View
Printer Status	Display printer status information, including the printer mode, the printer state, how long the printer has been powered on (in seconds), current conditions, and job status.	View	View
Supplies	Display information about the supplies currently installed in the printer. This includes the part number and serial number, additional codes that define the supply, and the percent of supply remaining in relation to a new full roll. Information displays for each module type.	View	View

Status Menu Option	Function	WebUser	WebAdmin
Audit Data	<p>Display card printer usage data, including card counts (both resettable—shown with an r as the first letter of the name—and non-resettable counts) and error reporting collected by the printer. This page acts as a general overview for all the counters and can be useful to track card production activity and problem history.</p>	View	View
Adapters	<p>Display information about the IP address configured for the printer. The page shows the IP address, network mask, gateway address, and MAC address.</p>	View	View
WiFi	<p>Display information about wireless connectivity if a Wi-Fi Dongle is installed in the printer.</p>	View	View
About Printer Manager	<p>Display the Printer Manager software version and copyright information.</p>	View	View

Printer Setting Menu

Use the **Printer Setting** menu to view and customize printer settings.

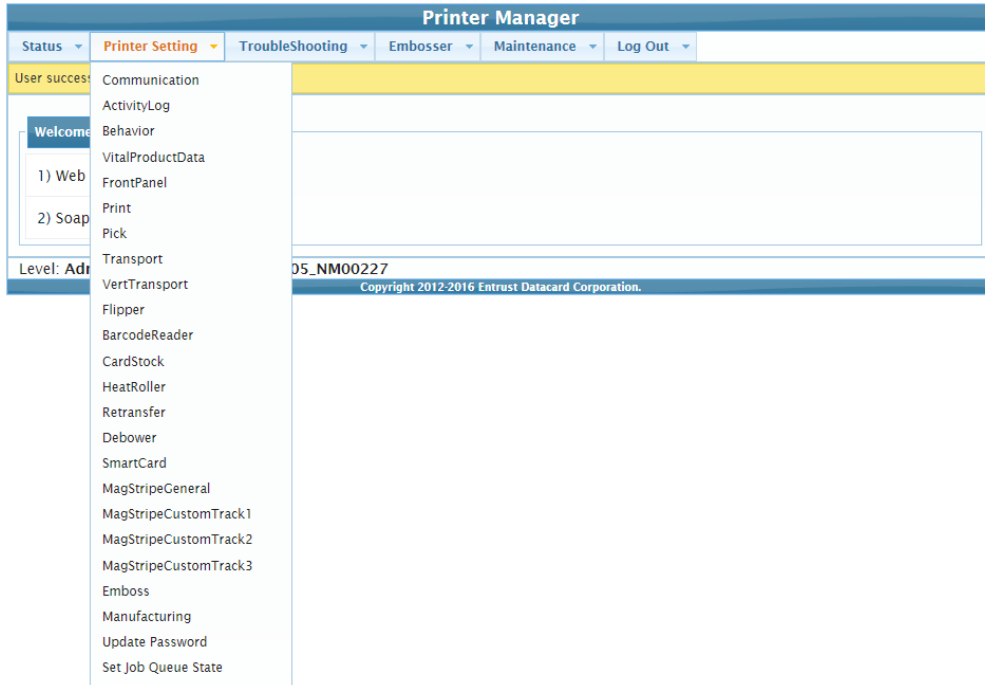

Printer Setting Menu Option	Function	WebUser	WebAdmin
Communication	Set or view the network address method used by the printer, including Cloud communication if it is enabled.	No	Change all Current Values
ActivityLog	Set values in the activity log to help isolate card production issues.	No	Change all Current Values
Behavior	Display printer operation and control methods.	No	Change all Current Values
VitalProductData	Change printer information. Available to WebService access level users only.	No	No

Printer Setting Menu Option	Function	WebUser	WebAdmin
FrontPanel	Set front panel values for the printer.	Change Backlight Brightness, KeySenseLevel and SpeakerEnabled values	Change all Current Values
Print	Select color mode and color profile settings, and set the supply rewind timeout period.	No	Change all Current Values
Pick	Display and set pick values. Most settings are available to WebService access level users only.	No	Change: SuppliesRequired
Transport	Specify card transport values and display the transport motor speed. and set card ejection values.	View only: TransMedSpeedMM	View only: TransMedSpeedMM Change other Current Values
VertTransport	Display the speed at which the vertical transport motor runs when clearing errors.	No	View: VertTransMedSpeed
Flipper	Set the reject tray capacity and values for the duplex module in duplex-option printers. Most settings are available to WebService access level users only.	No	Change: RejectHopper Capacity
BarcodeReader	Set the offset values for positioning a card to be read by the bar code reader.	No	Change all Current Values
CardStock	Set values for each type of card stock supported by the printer.	Change all Current Values	Change all Current Values
HeatRoller	Set time and temperature values for the heated roller.	Change all Current Values	Change all Current Values

Printer Setting Menu Option	Function	WebUser	WebAdmin
Retransfer	Set values for the retransfer process.	No	Change all Current Values
Debower	Set values for the debow action after the image has been transferred to the card. Available to WebService access level users only.	No	No
SmartCard	Set values for the smart card module in the printer. Available to WebService access level users only.	No	No
MagStripeGeneral	Set magnetic stripe options including coercivity, custom magnetic stripe formats, and data formats.	No	Change all Current Values
MagStripeCustomTrack1	Set customized magnetic stripe values for track 1.	No	Change all Current Values
MagStripeCustomTrack2	Set customized magnetic stripe values for track 2.	No	Change all Current Values
MagStripeCustomTrack3	Set customized magnetic stripe values for track 3.	No	Change all Current Values
Emboss (CE875 system only)	Set embosser values.	No	Change all Current Values
Multihopper	Available to WebService access level users only. This option displays only when a multi-hopper is attached to the printer.	No	No
Manufacturing	Available to WebService access level users only.	No	No
WifiNetworkStationSetup	Set Wi-Fi values. This option displays only when a Wi-Fi Dongle is installed in the printer.	No	Change all Current Values

Printer Setting Menu Option	Function	WebUser	WebAdmin
WifiModes	Enable or disable wireless communication. This option displays only when a Wi-Fi Dongle is installed in the printer.	No	Change all Current Values
Update Password	Set or update passwords for the WebUser and WebAdmin access levels.	No	Change WebUser and WebAdmin passwords
Set Job Queue State	Enter values for shipping the printer to a repair facility, or when securing the printer to perform troubleshooting, maintenance, or other procedures. This setting is used primarily by financial printers. Contact your service provider for more information.	Requires a password	Requires a password

Communication

Use the **Communication** settings to specify the network address method used by the printer.

Description	Default Value	Current Value (unit)	Allowed Range
1) CloudMQTTBrokerURI			
2) CloudMQTTKeepAlive	60	60	[1 – 360]
3) CloudMQTTPort	8883	8883	
4) CloudMQTTReceiveTopic			[1 – 65535]
5) CloudMQTTsocks5Host			
6) CloudMQTTsocks5Password			
7) CloudMQTTsocks5Port	3301	3301	[1 – 65535]
8) CloudMQTTsocks5Username			
9) CloudMQTTTemporaryURI			
10) EthAddressMethod	DHCP	DHCP	
11) EthDnsAddress1	0.0.0.0	0.0.0.0	
12) EthDnsAddress2	0.0.0.0	0.0.0.0	
13) EthDnsSearchSuffix			
14) EthGatewayAddress	0.0.0.0	10.2.71.1	
15) EthIpAddress	0.0.0.0	10.2.71.56	
16) EthSubnetMask	0.0.0.0	255.255.255.0	
17) IPMode	IPv4	DualStack	
18) IPv6DefaultGateway	::	::	
19) IPv6DHCPv6Select	Enabled	Enabled	
20) IPv6DNSPrimaryAddress	::	::	
21) IPv6DNSSecondaryAddress	::	::	

Description	Default Value	Current Value (unit)	Allowed Range
22) IPv6ManualAddress	::	::	
23) IPv6ManualPrefixLength	64	64	[0 – 128]
24) IPv6ManualSelect	Disabled	Disabled	
25) IPv6StatelessAddrSelect	Disabled	Disabled	



- The Cloud settings are supported only by certain Entrust software applications. Refer to your application documentation for information about using the cloud functions. Refer to “Behavior” on page 76 for information about enabling Cloud support.
- You can see the status of the Cloud connection using the printer LCD panel **Status** menu.
- **CloudMQTTBrokerURI**—Enter the URI to the cloud broker computer.
- **CloudMQTTKeepAlive**—Specify the maximum time (in seconds) for no communication between the cloud client (the printer) and the cloud broker. If the specified time is exceeded, the client must take action to determine if the connection to the broker is still active
- **CloudMQTTPort**—The port to use for cloud communication.
- **CloudMQTTReceiveTopic**—A list of optional topics, separated by semicolons, to subscribe to.
- **CloudMQTTSocks5Host**—Enter the IP address of the Socks5 proxy server.
- **CloudMQTTSocks5Password**—Enter the account password for the Socks5 proxy server.
- **CloudMQTTSocks5Port**—Enter the port number for the Socks5 proxy server.
- **CloudMQTTSocks5Username**—Enter the account name for the Socks5 proxy server.
- **CloudMQTTTemporaryURI**—When specified by the client, the printer disconnects from the primary cloud broker and connects to the temporary broker.

- **EthAddressMethod**—The method used to obtain the IPv4 network IP address. Select **DHCP** or **STATIC** from the Current Value drop-down list.
 - When the value is DHCP, the **EthGatewayAddress**, **EthIpAddress**, and **EthSubnetMask** values are controlled by the DNS server and the settings are filled in automatically.
 - When the value is STATIC, the **EthGatewayAddress**, **EthIpAddress**, and **EthSubnetMask** values must be set manually.
 - ◆ **EthGatewayAddress**—Enter the gateway address for the Ethernet network.
 - ◆ **EthIpAddress**—Enter the static IP address for the printer.
 - ◆ **EthSubnetMask**—Enter the subnet mask for the Ethernet network.
- **EthDnsAddress1**, **EthDnsAddress2**, **EthDnsSearchSuffix**—These settings are not used at this time.
- **IPMode**—Specify the IP mode used by the printer. The printer can support both IPv4 and IPv6 addressing. You can select from the following:
 - **IPv4**—The printer uses IPv4 addressing only.
 - **DualStack**—The printer can use both IPv4 and IPv6 addressing.

The remaining IPv6 settings become applicable when **IPMode** is set to **DualStack**.

- **IPv6DefaultGateway**—Set a default gateway address. This setting is disabled when set to the default of “:.”.
- **IPv6DHCPv6Select**—Select whether or not the printer obtains an address and stateful configuration from a DHCPv6 server. Disable this setting if a DHCPv6 server is not present.
- **IPv6DNSPrimaryAddress**, **IPv6DNSSecondaryAddress**—These settings are not used at this time.
- **IPv6ManualAddress**—Enter the IPv6 address using the following format:
xxxx:xxxx:xxxx:xxxx:xxxx:xxxx:xxxx:xxxx

Refer to [“Access Printer Manager”](#) on [page 61](#) for more information about entering an IPv6 address.

IPv6ManualSelect must be set to **Enabled** for the printer to use this setting.

- **IPv6ManualPrefixLength**—Specify the IPv6 manual subnet prefix length. IPv6 addresses consist of two parts. The prefix length indicates the boundary between the subnet to which the host is connected and device ID in the IPv6 manual address, starting from the left end. The default value is 64.

- **IPv6ManualSelect**—Enable the printer to use the manual address specified in **IPv6ManualAddress**. If this setting is disabled, the manual address information specified for the printer is retained, but is not used.
- **IPv6StatelessAddrSelect**—Enable the printer to allow the router to provide one or more network prefixes used for stateless automatic address configuration (SLAAC).

To modify the Communications settings:

1. Enter your changes in the **Current Value** fields.
2. Click **Set Current** to apply the changes.
3. Log out of Printer Manager, and then restart it for the changes to take effect.

ActivityLog

The **ActivityLog** settings allow you to record technical information about the printer. WebAdmin or WebService access-level users can change settings in the activity log to help troubleshoot and isolate a card production problem. You specify the types of actions to include in the logs and set the severity level for when the action should be written to the log. Filter severity level options are: Critical, Error, Warning, Notice, Information, Debug, Disabled.

Description	Default Value	Current Value (unit)
1) ExternalLog	Disabled	Disabled
2) ExternalLogServer	0.0.0.0	0.0.0.0
3) FilterCardActions	Notice	Notice
4) FilterConfigChanges	Notice	Notice
5) FilterJobStates	Notice	Notice
6) FilterSoapMsgs	Notice	Notice
7) FilterSystem	Notice	Notice
8) InternalLog	Enabled	Enabled

- **ExternalLog**—Enable or disable writing the activity log to an external Syslog server.
- **ExternalLogServer**—Specify the IP address of the external Syslog server if you are writing to an external log (ExternalLog is set to Enabled).
- **FilterCardActions**—Write the start and completion of a card action with the specified severity, and higher, to the activity log.
- **FilterConfigChanges**—Write configuration change actions with the specified severity, and higher, to the activity log.
- **FilterJobStates**—Write changes to the state of a print or exception job with the specified severity, and higher, to the activity log.
- **FilterSoapMsgs**—Write DPCL/Soap (Simple Object Access Protocol) messages from the printer with the specified severity, and higher, to the activity log.
- **FilterSystem**—Write system information with the specified severity, and higher, to the activity log. A value of Information results in most events being written to the log.
- **InternalLog**—Enable or disable the activity log on the printer.



We recommend that you operate at all default logging settings to reduce unnecessary logging for typical printer operations.

Activity Log Example:

Change the FilterJobStates status recorded in the activity log to help isolate a card production problem.

1. Select **Printer Setting > Activity Log**.
2. Set **FilterJobStates** to **Error** from the drop-down list. Changes to the state of a job, with this severity and higher, are written to the activity log.
3. Click **Set Current** to apply the changes.

The screenshot shows the 'Printer Manager' interface with the 'ActivityLog' tab selected. A table lists various configuration items with their default and current values. The 'FilterJobStates' item is highlighted, and its dropdown menu is open, showing 'Error' as the selected option.

Description	Default Value	Current Value (unit)
1) ExternalLog	Disabled	Disabled
2) ExternalLogServer	0.0.0.0	0.0.0.0
3) FilterCardActions	Notice	Notice
4) FilterConfigChanges	Notice	Notice
5) FilterJobStates	Notice	Error
6) FilterSoapMsgs	Notice	Notice
7) FilterSystem	Notice	Notice
8) InternalLog	Enabled	Enabled

Level: AdminAccess | Hostname: NM00104
Copyright 2012-2016 Entrust Datacard Corporation.

Behavior

Use the Printer Setting menu **Behavior** settings to control printer operation.

Description	Default Value	Current Value (unit)	Allowed Range
1) ActivityLogExternal	Enabled	Enabled	
2) ActivityLogInternal	Enabled	Enabled	
3) CloudEnable	Disabled	Disabled	
4) ContactAutoDetect	Disabled	Disabled	
5) ContactlessATRMMode	Legacy	Legacy	
6) DoorCloseLockTimeout	5	5	[0 – 15]
7) DPCL	Enabled	Enabled	
8) DPCL2	Enabled	Enabled	
9) DPCL2Secure	Enabled	Enabled	
10) DPCLSecure	Enabled	Enabled	
11) Plugin	Enabled	Disabled	
12) RejectCardLocation	Automatic	Automatic	
13) Remake	Enabled	Disabled	
14) RetrieveDataTimeout	120	120	[0 – 120]
15) SmartcardDefaultShareMode	Direct	Direct	
16) SmartcardForceProtocol	Disabled	Disabled	
17) SmartcardPostConnectDelay	400	400	[0 – 5000]
18) SmartcardSwitchModeDelay	3000	3000	[0 – 5000]
19) WebServerSecure	Enabled	Enabled	

Update Current Values as needed, and then click **Set Current** to apply the changes.

- **ActivityLogExternal**—Enable or disable writing the activity log to an external server.
- **ActivityLogInternal**—Enable or disable the internal activity log.
- **CloudEnable**—Enable or disable printer Cloud support.



You also can enable Cloud support using the printer LCD panel **Configuration** menu.

- **ContactAutoDetect**—This setting supports legacy smart card clients. It overrides the smart card protocol sent by the client to the printer and uses SCARD_PROTOCOL_TO_OR_T1. The setting is set to **Disabled** by default.
- **ContactlessATRMode**—Select the default ATR mode for the DUALi contactless smart card reader. The possible values are:
 - **Vendor**—Uses the ATR mode specified by the vendor. The generated ATR may not be compatible with all smart card applications or card types.
 - **PCSC**—Uses the PC/SC protocol to generate the ATR.
 - **CCID**—Uses the CCID protocol to generate the ATR.
 - **Legacy**—Uses the ATR mode currently in use by the reader. This is the default value.
 - **AppSpecifies**—Allows the smart card application to control the ATR mode.



A smart card application may specify to receive the ATR in a different format regardless of this setting. However, when the printer restarts, the smart card reader returns to the setting specified here. Consider whether you want to specify the format on a job-by-job basis or modify the Printer Manager setting to use the desired ATR format.

- **DoorCloseLockTimeout**—The number of seconds after all printer doors are closed before the printer is locked. The timeout period starts when all the doors are closed. Use this setting to override the default lock timeout period, which starts when the printer is unlocked electronically from an application. This setting does not apply if you use a key to unlock the printer.
- **DPCL**—Enable or disable DPCL command access to the printer through the non-secure port.
- **DPCL2**—Enable or disable DPCL2 command access to the printer through the non-secure port.
- **DPCL2Secure**—Enable or disable DPCL2 command access to the printer through the secure port.



To ensure that DPCL2Secure is always used for secure communication with the printer, set DPCL2 to Disabled.

- **DPCLSecure**—This setting is not used by the printer.
 - **Plugin**—Enable or disable the plugin feature for the printer to access an installed plug-in. This setting does not apply to all printers.
 - **RejectCardLocation**—Specify where to place rejected cards. You can select from the following options:
 - **Automatic:** Rejected cards are placed in the reject tray. This is the default setting.
 - **OutputHopper:** Rejected cards are placed in the output hopper.
-  If the system includes an additional component, such as an embosser, rejected cards are placed in the component reject tray and the RejectCardLocation setting does not apply.
- **Remake**—Enable or disable card remakes. If Remake is set to Enabled and a print request fails, the print request is tried again with a new card. A card is retried only once.
 - **RemakeMethod**—Select the card remake method. This setting does not display if Remake is set to Disabled.
 - Select **ConserveSupplies** to reprint the card out of queue order.
 - Select **PreserveOrder** to reprint the card in queue order.
 - **RetrieveDataTimeout**—Specify the time period during which card data can be retrieved. You can specify from 0 to 120 seconds. If the Current Value is 0, data is not retrieved.
 - **SmartcardDefaultShareMode**—Specify the share mode used by an application for the smart card reader. You can select from the following options:
 - **Direct:** The application allocates the smart card reader for its private use and controls it directly. No other application is allowed to access the reader. This is the default setting.
 - **Shared:** The application can share the smart card reader with other applications. Some applications may require that the smart card reader is shared.
 - **SmartcardForceProtocol**—The smart card reader normally auto-detects the protocol to use to communicate with the smart card chip. However, if a smart card application changes protocols, the smart card reader may continue to try to communicate using the previous protocol. Use this setting to override auto-detection of the communication protocol, if necessary. You can select from the following options:
 - **Disabled:** No override, the smart card reader auto-detects the protocol to use. This is the default setting.
 - **T0:** Force the protocol to T=0 (asynchronous half-duplex byte transmission).
 - **T1:** Force the protocol to T=1 (asynchronous half-duplex block transmission protocol).

- **SmartcardPostConnectDelay**—The number of milliseconds to wait after the smart card reader connects or reconnects before sending the next command. This setting applies only to Duali single-wire smart card readers.
- **SmartcardSwitchModeDelay**—The number of milliseconds to wait after the share mode is switched to give the smart card reader time to switch modes before attempting communication. This setting applies only to Duali single-wire smart card readers.
- **WebServerSecure**—Enable or disable access to Printer Manager (the web server) through the secure port.



Caution: Do not disable WebServerSecure. If the web server is disabled, you cannot launch Printer Manager and configuration changes cannot be made. To reverse this action, you must contact Entrust. To restrict access for the WebAdmin access level, select **Printer Setting > Update Password** and specify a password. Refer to [“Update Password”](#) on [page 102](#).

VitalProductData

The **VitalProductData** settings allow WebService access level users to change information about the printer or system in specific circumstances. Contact your service provider should it become necessary to modify the VitalProductData settings.

FrontPanel

Use the **FrontPanel** settings to customize the printer front panel.

Description	Default Value	Current Value (unit)	Allowed Range
1) BacklightBrightness	100	100	[0 – 100]
2) KeySenseLevel	5	5	[0 – 10]
3) LcdConfigMenu	Enabled	Enabled	
4) LedCardsPickedToCleaning	500	500	[0 – 1000000]
5) LedPrintheadCyclesToCleaning	2500	2500	[0 – 1000000]
6) LedRibbonLow	10	10	[0 – 1000000]
7) SpeakerEnabled	Enabled	Enabled	

Change the front panel settings as needed, and then click **Set Current** to apply the changes.

- **BacklightBrightness**—Set the LCD front panel backlight brightness at the desired level, from **0** percent (no backlight) to **100** percent (bright).
- **KeySenseLevel**—Set the front panel key sensitivity to a comfortable level. Select from **0** (low sensitivity, almost a press) to **10** (high sensitivity, barely a touch).
- **LcdConfigMenu**—Enable or disable access to the Configuration menu on the LCD panel menu system. (The Status and Maintenance menus cannot be disabled.)
- **LedCardsPickedToCleaning**—Set the number of cards to pick between required cleaning. The card light blinks amber when the printer reaches this value. If this value is set to 0, cards between cleaning are not tracked. Best practices recommend that you clean the printer each time you change the ink ribbon, or more often depending on your environment or if the print quality diminishes.
- **LedPrintheadCyclesToCleaning**—Set the number of printhead cycles between required cleaning. The card light blinks amber when the printer reaches this value. If this value is set to 0, cycles between cleaning are not tracked.
- **LedRibbonLow**—Set the percentage of ribbon remaining before being notified that the ribbon is low and should be changed. The ribbon light blinks amber when the ribbon reaches this value.
- **SpeakerEnabled**—Enable or disable the external printer speaker. The speaker provides a sound in addition to the front panel lights and LCD text.

Print

Use the **Print** menu to select a color mode and color management profile for printing. You also can specify the time the printer is idle before the ink ribbon and retransfer film are rewound to protect them from accumulating dust.

Description	Default Value	Current Value (unit)	Allowed Range
1) CMSEmulationVersion	R4_7	R4_7	
2) CMSMode	Current	Current	
3) ColorMode	TrueColor (ICC)	TrueColor (ICC)	
4) FilmPreregisterProcess	Original	Original	
4) SettingsGroupPurpose	Print	Print	
5) TimeoutRewindSupply	0	0	[0 – 120]

Change settings as needed, and then click **Set Current** to apply the changes.

- **CMSEmulationVersion**—The **CMSEmulationVersion** and **CMSMode** settings work together to adjust the color printing across firmware versions. Changes in the color calibration method used by the printer can result in slight shifts in color following a firmware upgrade. These settings allow you to restore the color management profile used by the printer after an upgrade to that used by an earlier firmware version. As future firmware versions are released, additional emulation versions will be added to the list.
- **CMSMode**—Specify the color management profile the printer should use. Possible values are:
 - **Current:** Use the color management profile specified by the current firmware version. When **CMSMode** is set to **Current**, the **CMSEmulationMode** setting is not used. This is the default setting.
 - **Emulation:** Use the color management profile specified by the **CMSEmulationVersion** setting.

- **ColorMode**—Select the color mode that best defines the color printing requirements for your site. You can select from the following:
 - **TrueColor (ICC)**. Uses a color profile that has been calibrated to closely match the output produced by the Entrust Artista® VHD Retransfer Color Printing Module Gen 2.
 - **Legacy SR/CR**. Processes the input colors to provide print output that is similar to that produced by Entrust SR200/SR300/CR500 card printers. The printed card will not be identical because of differences in the print resolution and canvas size used by the CR825 or CE875 printer. You may need to modify your existing card designs to produce the optimal output.
 - **Legacy SR300 LUT**. Processes the input colors to provide print output that is similar to that produced by the Entrust SR300 card printer when it uses a color lookup table (LUT).
 - **Vivid**. Produces darker, more saturated color on the printed card. It is based on the TrueColor (ICC) setting.
- **FilmPreregisterProcess**—Sets the location of the retransfer film index mark at initialization and at the end of a print job. Possible values are:
 - **Original**: The retransfer film index mark is positioned so that it does not block the film sensor.
 - **StopOnIndexMark**: The retransfer film index mark is positioned so that it blocks the film sensor. Primerless ribbon always uses the StopOnIndexMark value to reduce wrinkling in the retransfer film.
- **SettingsGroupPurpose**—State the purpose of a settings group. Group names are not changeable. Use this option to identify the reason for creating a settings group.
- **TimeoutRewindSupply**—Specify the number of minutes of idle time before the printer rewinds the ink ribbon and retransfer film to protect them from dust. If the ribbon and retransfer film are left exposed, a static charge on the supplies attracts dust from the air. The printer rewinds the ink ribbon and retransfer film at the end of the specified time. The supplies unwind again when the next card is sent to the printer. The default setting of zero (0) minutes turns off the rewind process. The rewind does not occur if a job is running or the printer door is open.

Contact your service provider for more information about when to use the supply rewind feature and recommended settings.



Using the supply rewind feature can reduce the number of cards printed with a ribbon.

Pick

The **Pick** settings define how cards are picked from the input hopper. Most **Pick** settings are available for WebService access-level users only. Contact your service provider for information about changing the printer's pick settings.

WebAdmin access-level users can specify whether the pick action fails when supplies are not installed in the printer or if a supply has an error condition. The setting also prevents the printer from producing a blank card if the supply information is not valid. WebAdmin users also can specify whether a warning message displays if the card stock is not compatible with the primerless ink ribbon.

Description	Default Value	Current Value (unit)
1) EnableFilmAndCardMismatchWarnings	Enabled	Enabled
2) SuppliesRequired	Enabled	Enabled

Change the setting, as needed, and then click **Set Current** to apply the change.

- **EnableFilmAndCardMismatchWarnings**—Specify if a warning message displays if the card stock is not compatible with the primerless ribbon. Primerless ribbon should only be used with PVC or composite cards. Possible values are:
 - **Enabled:** Displays a warning message if the card stock is not compatible with the ink ribbon. Refer to “[Card Material](#)” on [page 114](#).
 - **Disabled:** A warning message does not display.
- **SuppliesRequired**—Specify if the pick action succeeds or fails when supplies are removed from the printer. Possible values are:
 - **Enabled:** The pick action fails if either one or both of the supplies (ink ribbon and retransfer film) are not installed in the printer. The pick action also fails if the supplies are installed but one supply has an error condition.
 - **Disabled:** The pick action succeeds if one or both of the supplies are removed. However, the pick action fails if an installed supply has an error condition.

Transport

The **Transport** settings control card travel through the printer. Most settings are available for Webservice access-level users only. WebAdmin users can set values for ejecting a card from the printer

Description	Default Value	Current Value (unit)	Allowed Range
1) EjectTries	3	3	[1 – 4]
2) FinalEjectSpeed	Normal	Normal	
3) TransMedSpeedMM	67.733	67.733	[25.4 – 200.0]

Change settings as needed, and then click **Set Current** to apply the changes.

- **EjectTries**—Specify the number of attempts (automatic retries) the printer makes to eject a card through the output hopper. The first attempt to eject a card uses the speed specified in the Webservice **TransportSpeedMM** setting. Subsequent attempts use the value specified in **FinalEjectSpeed**.

A value of 0 specifies that the printer does not check if the card was ejected and does not make additional attempts to eject the card.

- **FinalEjectSpeed**—Select the speed at which to eject cards. Possible values are:
 - **Normal**: The speed used to eject a card is 125 motor steps/second. This is the default value specified in **TransportSpeedMM**.
 - **High**: The speed used to eject a card is 138 motor steps/second.
- **TransMedSpeedMM**—The speed at which the transport motor runs when clearing errors. You cannot change this value.

VertTransport

The **VertTransport** setting controls the speed at which the vertical transport motor runs when clearing errors.

Description	Default Value	Current Value (unit)	Allowed Range
1) VertTransMedSpeed	67.733	67.733	[25.4 – 200.0]

- **VertTransMedSpeed**—The speed at which the vertical transport motor runs when clearing errors. You cannot change this value.

Flipper

The **Flipper** settings define values for the duplex module in duplex-option printers. Most Flipper settings are available for WebService access-level users only. Contact your service provider for assistance if you need to change the printer's flipper settings.

WebAdmin access-level users can specify the number of cards that are allowed in the reject tray before an error is issued.

Description	Default Value	Current Value (unit)	Allowed Range
1) RejectHopperCapacity	6	6	[5 – 15]

Change the setting, as needed, and then click **Set Current** to apply the change.

- **RejectHopperCapacity**—The number of cards allowed in the printer reject tray before the reject tray full message is issued. The capacity of the reject hopper depends on the thickness of the card stock being used.



If the system includes an additional component, such as an embosser, rejected cards are placed in the component reject tray and the RejectHopperCapacity setting does not apply.

BarcodeReader

The **BarcodeReader** settings define values for the optional bar code reader used by some printers to read and verify the bar code on pre-serialized cards. The bar code location can vary, depending on the card. These settings allow you to adjust the imaging position for the bar code so that it can be read.

Description	Default Value	Current Value (unit)	Allowed Range
1) LeadingCardEdgeToBarcodeMM	2.9	2.9	[0 – 50.0]
2) SensorToLeadingCardEdgeMM	37.0	37	[30.0 – 44.0]

Change the settings, as needed, and then click **Set Current** to apply the change.

- **LeadingCardEdgeToBarcodeMM**—The distance, in millimeters, from the leading edge of the card to the beginning of the bar code. The printer uses this value to position the card so the bar code is within the imaging area. Enter a value of 50 if the measured distance to the bar code is greater than 50 mm.

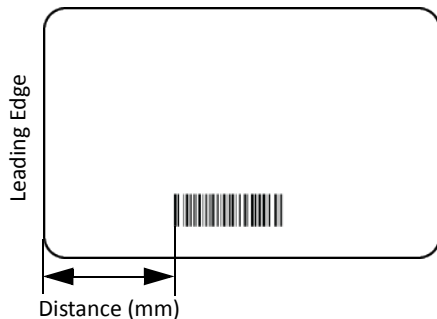

- **SensorToLeadingCardEdgeMM**—The distance, in millimeters, from the card sensor to the leading edge of the card. Use the default value unless directed otherwise by technical support.

CardStock

Use the **CardStock** settings to define values for the different types of card stock that can be loaded in the printer.

Description	Default Value	Current Value (unit)	Allowed Range
1) CardStockDisplayed		CardStock1	
DebowDistance	37	37	[0 – 42]
DebowDwell	1000	1000	[0 – 5000]
DirectPeelLaminationSpeed	15.0	15	[10.0 – 34.0]
ExceptionCardStockLoaded		CardStock1	
Hopper(1–6)CardStockLoaded		CardStock1	
ImpressDepthOffset[0-9]	0	0	[-2000 – 2000]
ImpressDwellTimeOffset[0-9]	0	0	[-1000 – 1000]
ImpressTemperatureOffset[0-9]	0	0	[-200 – 200]
RetransferCoolTime	0	0	[0 – 10000]
RetransferLaminationSpeed	10.0	12	[10.0 – 34.0]
RetransferLaminationSpeed Layer2	15.0	15	[10.0 – 34.0]
RetransferLaminationSpeed Layer2Side2	15.0	15	[10.0 – 34.0]
RetransferLaminationSpeed Side2	10.0	12	[10.0 – 34.0]
RetransferRollerTemp	165	165	[140 – 190]
RetransferRollerTempSide2	165	165	[140 – 190]
V2RetransferLaminationSpeed	10.0	10	[10.0 – 34.0]
V2RetransferLaminationSpeed Layer2	15.0	15	[10.0 – 34.0]
V2RetransferLaminationSpeed Layer2Side2	15.0	15	[10.0 – 34.0]

Description	Default Value	Current Value (unit)	Allowed Range
V2RetransferLaminationSpeedSide2	10	10	[10.0 – 34.0]
V2RetransferRollerTemp	165	165	[140 – 190]
V2RetransferRollerTempSide2	165	165	[140 – 190]

Change settings as needed, and then click **Set Current** to apply the changes.

- **CardStockDisplayed**—Select the card stock whose settings you want to view and change on this page. Click **Set Current** to apply the card stock. You must do this before making any changes to the card stock settings. The changes you make to the settings on this page apply to the selected card stock. Click **Set Current** again to save your changes.

The settings apply whenever the named card stock is loaded in the printer, as specified in **Hopper(1–6)CardStockLoaded** or **ExceptionCardStock Loaded**.

You can define up to 10 card stock types.

- **DebowDistance**—The distance necessary to debow the specified card type. You can set a different value for each card stock specified in **CardStockDisplayed**.
- **DebowDwell**—The time, in milliseconds, to apply the debow action to the specified card stock. You can set a different value for each card stock specified in **CardStockDisplayed**.
- **DirectPeelLaminationSpeed**—The speed at which to apply the retransfer film to side 2 of the card if the card design includes inhibitor or smart card programming. The setting applies to the card stock specified in **CardStockDisplayed**.
- **ExceptionCardStockLoaded**—The card stock that will be inserted in the exception slot.
- **Hopper(1–6)CardStockLoaded**—The card stock loaded in the input hopper. If a multi-hopper is installed, you can specify a different card stock for each hopper cartridge.
- **ImpressDepthOffset**—This setting currently is not used by the printer.
- **ImpressDwellTimeOffset**—This setting currently is not used by the printer.
- **ImpressTemperatureOffset**—This setting currently is not used by the printer.
- **RetransferCoolTime**—The time, in milliseconds, to allow the card to cool after the retransfer completes.
- **RetransferLaminationSpeed**—The speed at which to apply the retransfer film to side 1 of the card for the card stock specified in **CardStockDisplayed**.
- **RetransferLaminationSpeedLayer2**—The speed at which to apply the second layer of retransfer film to side 1 of the card. The setting applies to the card stock specified in **CardStockDisplayed**.

- **RetransferLaminationSpeedLayer2Side2**—The speed at which to apply the second layer of retransfer film to side 2 of the card. The setting applies to the card stock specified in **CardStockDisplayed**.
- **RetransferLaminationSpeedSide2**—The speed at which to apply the retransfer film to side 2 of the card if the card design does not include inhibitor or smart card programming. The setting applies to the card stock specified in **CardStockDisplayed**.
- **RetransferRollerTemp**—The temperature (in degrees Celsius) of the heated roller when applying the retransfer film to side 1 of the card stock specified in **CardStockDisplayed**. The heated roller remains at the specified temperature.
- **RetransferRollerTempSide2**—The temperature (in degrees Celsius) of the heated roller when applying the retransfer film to side 2 of the card stock specified in **CardStockDisplayed**. The heated roller remains at the specified temperature.

The following settings are used when a ribbon without a primer (P) panel is installed in the printer. The primerless ribbon requires a compatible retransfer film and is supported only for PVC or composite card stock.

- **V2RetransferLaminationSpeed**—The speed at which to apply the retransfer film to side 1 of the card for the card stock specified in **CardStockDisplayed**.
- **V2RetransferLaminationSpeedLayer2**—The speed at which to apply a second layer of retransfer film to side 1 of the card.
- **V2RetransferLaminationSpeedLayer2Side2**—The speed at which to apply a second layer of retransfer film to side 2 of the card.
- **V2RetransferLaminationSpeedSide2**—The speed at which to apply the retransfer film to side 2 of the card. The setting applies to the card stock specified in **CardStockDisplayed**.
- **V2RetransferRollerTemp**—The temperature (in degrees Celsius) of the heated roller when applying the retransfer film to side 1 of the card stock specified in **CardStockDisplayed**. The heated roller remains at the specified temperature.
- **V2RetransferRollerTempSide2**—The temperature (in degrees Celsius) of the heated roller when applying the retransfer film to side 2 of the card stock specified in **CardStockDisplayed**. The heated roller remains at the specified temperature.

HeatRoller

The **HeatRoller** settings specify the time the printer is idle before it reduces its temperature and when power to the heated roller is turned off.

Description	Default Value	Current Value (unit)	Allowed Range
1) HeaterMinutesToLowPower	5	5	[0 – 240]
2) HeaterMinutesToPowerSave	15	15	[0 – 240]
3) LowPowerRollerTemp	135	135	[20 – 160]

Change settings as needed, and then click **Set Current** to apply the changes.

- **HeaterMinutesToLowPower**—The number of minutes the printer is idle before the heated roller reduces its temperature to the value specified in the **LowPowerRollerTemp** setting. (The heated roller is turned off after the time specified in **HeaterMinutesToPowerSave**.)
- **HeaterMinutesToPowerSave**—The number of minutes of printer idle time before the heated roller is turned off. After waiting the specified number of minutes, the roller is allowed to cool down. A value of 0 allows the roller to start cooling down immediately.

Using power save requires a brief warm-up period before the printer is ready to print cards again. The front panel LCD displays the message **Busy Warming up** and a percentage that indicates the status of the heated roller.

- **LowPowerRollerTemp**—The temperature to which the heated roller is lowered after the number of minutes of idle time specified in **HeaterMinutesToLowPower**.

Retransfer

The **Retransfer** settings define values for the retransfer process.

Description	Default Value	Current Value (unit)	Allowed Range
1) BacksideCoolingDelay	0	0	[0 – 120]
2) EmbosserHandoffCooling Delay	0	0	[0 – 120]
3) LaminatorHandoffCooling Delay	0	0	[0 – 120]
4) RetransferVersion	Version1	Version1	
5) SecondRetransferCooling Delay	20	20	[0 – 120]

Change settings as needed, and then click **Set Current** to apply the changes.

- **BacksideCoolingDelay**—The number of seconds that the card remains in the flipper to cool between front side and back side retransfer.
- **EmbosserHandoffCoolingDelay**—The number of seconds the card remains in the printer before it is moved into the embosser. This allows the card time to cool before moving into the embosser. This setting applies only to systems with an embosser.
- **LaminatorHandoffCoolingDelay**—The number of seconds the card remains in the printer before it is moved into the laminator. This allows the card time to cool before moving into the laminator. This setting applies only to systems with a laminator.
- **RetransferVersion**—The retransfer process used by the printer. Versions 1 and 2 are used when ribbons with a primer panel are installed in the printer. Printers with primerless ribbons always use Version 3, regardless of the version specified in this setting.
- **SecondRetransferCoolingDelay**—The number of seconds that the card is allowed to cool before a second layer of retransfer film is applied.

Debower

The heat from the retransfer process can cause the card to become bowed slightly. The debower returns the card to its proper shape. The **Debower** settings define values for the debow action performed after the image has been transferred to the card. Debower settings are available for WebService access-level users only. Contact your service provider for assistance if you need to change the printer's debower settings.



Cards are debowed after each retransfer operation.

SmartCard

The **SmartCard** settings define values for the smart card module in the printer. SmartCard settings are available to WebService access-level users only.

MagStripeGeneral

Magnetic stripe settings are available for WebAdmin and WebService access-level users to set up basic magnetic stripe options.

Description	Default Value	Current Value (unit)	Allowed Range
1) Attempts	3	3	[1 – 5]
2) Coercivity	HICO	HICO	
3) DataFormat1	IATA	IATA	
4) DataFormat2	ABA	ABA	
5) DataFormat3	TTS	TTS	
6) NoDataDisableTrack	Disabled	Disabled	
7) ReadTrack1	Enabled	Enabled	
8) ReadTrack2	Enabled	Enabled	
9) ReadTrack3	Enabled	Enabled	
10) SSA1	0	0	[-4 – 4]
11) SSA2	0	0	[-4 – 4]
12) SSA3	0	0	[-4 – 4]
13) StripeEncoderMultiplier	1.0	1	[0.9 – 1.1]
14) WriteTrack1	Enabled	Enabled	
15) WriteTrack2	Enabled	Enabled	
16) WriteTrack3	Enabled	Enabled	

Change settings as needed, and then click **Set Current** to apply the changes.

- **Attempts**—Specify the number of attempts (automatic retries) the printer makes to encode the magnetic stripe data. This value also is used for the number of times to attempt to read magnetic stripe data.

If you set this number to a lower value, it increases the throughput of the printer but can decrease the reliability of magnetic stripe encoding.

If you set the number to a higher value, it decreases the throughput of the printer but can increase the reliability of magnetic stripe encoding.

A value of 1 means no retry attempts.

- **Coercivity**—Select the coercivity setting that matches the cards you are using. Coercivity measures the resistance of magnetic material to the removal of encoded data. High coercivity (HICO) requires more electrical force to encode data and the data is more resistant to magnetic interference. The choices are **HICO**, **LOCO**, **NTT1**, **NTT2**, **NTT3**.

- **DataFormat (1, 2, 3)**—Specify the names of the data formats used for tracks 1, 2, and 3.

For single-track magnetic stripe encoding, set **DataFormat3** to **JIS** and **DataFormat1** and **DataFormat2** to **NONE**.

To use a custom data format, define the formats for tracks 1, 2, and/or 3 using the **MagStripeCustomTrack (1, 2, 3)** settings and then set the corresponding **DataFormat** settings to **CUSTOM**.

- **NoDataDisableTrack**—Disable the magnetic stripe write head for a track if the track contains no data. When this is disabled, any track that was not given data is erased.
- **ReadTrack (1, 2, 3)**—Allow magnetic stripe read actions to read from tracks 1, 2, and 3.
- **SSA (1, 2, 3)**—Set the start sentinel adjustment for tracks 1, 2, and 3. (SSA3 also sets the start sentinel for a single track.) The start sentinel is encoded on the magnetic stripe immediately before the first data character and indicates the beginning of data. Enter a value from -4 to 4.
- **StripeEncoderMultiplier**—This value is information only and cannot be changed. It is determined when an SSA test is run.
- **WriteTrack (1, 2, 3)**—Allow magnetic stripe write actions to write to tracks 1, 2, and 3.

MagStripeCustomTrack 1–3

Custom magnetic stripe settings are available for WebAdmin and WebService access-level users to define custom magnetic stripe options.

Description	Default Value	Current Value (unit)	Allowed Range
1) CustomCharHigh	Track 1: 95 Tracks 2 & 3: 63	95 63	[0 – 255]
2) CustomCharLength	Track 1: 6 Tracks 2 & 3: 4	6 4	[1 – 8]
3) CustomCharLow	Track 1: 32 Tracks 2 & 3: 48	32 48	[0 – 255]
4) CustomCharMask	Track 1: 32 Track 2: 48	32 48	[0 – 255]
5) CustomCharMax	Track 1: 76 Track 2: 37 Track 3: 104	76 37 104	[0 – 255]
6) CustomDensity	Tracks 1 & 3: 210 Track 2: 75	210 75	[0 – 255]
7) CustomEndSentinel	63	63	[0 – 255]
8) CustomLrc	EVEN	EVEN	
9) CustomParity	ODD	ODD	
10) CustomSdsNulls	0	0	[0 – 255]
11) CustomSdsRecords	1	1	[0 – 255]
12) CustomSdsSs	1	1	[0 – 255]
13) CustomStartSentinel	Track 1: 37 Tracks 2 & 3: 59	37 59	[0 – 255]

Change settings as needed, and then click **Set Current** to apply the changes.

- **CustomCharHigh**—Specify the numeric value of the highest ASCII character supported for input data on the track.
- **CustomCharLength**—Set the number of bits to represent one character of data on the track, also called bits per character.
- **CustomCharLow**—Specify the numeric value of the lowest ASCII character supported for input data on the track.
- **CustomCharMask**—Specify the mask value that is subtracted from the ASCII numeric value to get the encoded value.
- **CustomCharMax**—Specify the maximum number of data characters for the track. The value does not include the start sentinel or end sentinel.
- **CustomDensity**—Specify the number of data bits per inch of magnetic stripe media for the track, also called bits per inch or bpi. Allowed values are 75 bpi or 210 bpi.
- **CustomEndSentinel**—Specify the last character encoded, which identifies the end of encoded data for the track.
- **CustomLrc**—Specify a cumulative parity bit that is encoded after the end sentinel to provide simple error checking. Allowed values are EVEN, ODD, and NONE.
- **CustomParity**—Specify a character-level parity bit encoded after each character to provide simple error checking. Allowed values are EVEN, ODD, and NONE.
- **CustomSdsNulls**—The number of nulls between each copy of the data record. You should not change this value.
- **CustomSdsRecords**—The number of times to encode the data record. You should not change this value.
- **CustomSdsSs**—The number of start sentinels before each data record. You should not change this value.
- **CustomStartSentinel**—Specify the first character encoded, which identifies the start of the encoded data for the track.

Using custom magnetic stripe data formats is a two-step process. First, define the custom tracks using **MagStripeCustomTrack1**, **MagStripeCustomTrack2**, and **MagStripeCustomTrack3**. Second, apply the custom track using the settings on the MagStripeGeneral menu.

1. To use the defined custom track:
 - a. Open the **MagStripeGeneral** menu.
 - b. Select Custom for **DataFormat1**, **DataFormat2**, or **DataFormat3** to use the custom track.
 - ◆ MagStripeCustomTrack1 corresponds to DataFormat1
 - ◆ MagStripeCustomTrack2 corresponds to DataFormat2
 - ◆ MagStripeCustomTrack3 corresponds to DataFormat3
2. Click **Set Current** to apply the changes.

Emboss

The **Emboss** settings let you specify values when using an embossing system.



The Emboss setting displays in the Printer Setting menu only for a CE875 instant issuance system.

Description	Default Value	Current Value (unit)	Allowed Range
1) RegistrationXDist	0	0	[-100 – 100]
2) TopperDwell	850	850	[100 – 2000]
3) TopperTemperature	121	121	[0 – 127]

1. Enter a value (within the allowable range) in the Current Value column.
 - **RegistrationXDist**—The distance at which the card is registered at home inside of the embosser. Select from -100 to 100 motor steps.
 - **TopperDwell**—The length of time (dwell) in which the topping module applies topping foil to the embossed characters. Select from 100 to 2000 milliseconds.
 - **TopperTemperature**—The temperature, in degrees Celsius, at which the topping module applies topping foil to the embossed characters. Select from 0 to 127 degrees C.
2. Click **Set Current** to apply the changes.

Multihopper

The **Multihopper** settings define values for the multi-hopper. **Multihopper** settings are available to WebService access-level users only.



The Multihopper option displays in the Printer Setting menu only when a multi-hopper is attached to the printer.

Manufacturing

The **Manufacturing** settings define values for card movement in the printer. **Manufacturing** settings are available to WebService access-level users only.

WifiNetworkStationSetup



- The **WifiNetworkStationSetup** option displays in the Printer Setting menu only when a Wi-Fi Dongle is installed in the printer.
- Enter these values before enabling wireless communication using the **WifiModes** settings.

The **WifiNetworkStationSetup** settings allow you to configure the Wi-Fi Dongle.

Description	Default Value	Current Value (unit)
1) WifiAddressMethod	DHCP	DHCP
2) WifiDnsAddress1	0.0.0.0	0.0.0.0
3) WifiDnsAddress2	0.0.0.0	0.0.0.0
4) WifiDnsSearchSuffix		
5) WifiGatewayAddress	0.0.0.0	0.0.0.0
6) WifiIpAddress	0.0.0.0	0.0.0.0
7) WifiMacAddress		00:0e:8e:76:9f:ec
8) WifiPassword		
9) WifiSecurityMode	None	None
10) WifiSSID		
11) WifiSubnetMask	0.0.0.0	0.0.0.0

Change the settings, and then click **Set Current** to apply the changes.

- **WifiAddressMethod**—The method used to obtain the Wi-Fi network IP address. Select either **DHCP** or **STATIC** from the drop-down list. The default value is DHCP.
 - When the value is DHCP, the **WifiGatewayAddress**, **WifiIpAddress**, and **WifiSubnetMask** values are controlled by the DNS server and the settings are filled in automatically.
 - When the value is STATIC, the **WifiGatewayAddress**, **WifiIPAddress**, and **WifiSubnetMask** values must be entered manually. Obtain these values from your network administrator.
 - ◆ **WifiGatewayAddress**—Enter the gateway address for the Wi-Fi network.
 - ◆ **WifiIpAddress**—Enter the static IP address for the printer.
 - ◆ **WifiSubnetMask**—Enter the subnet mask for the Wi-Fi network.
- **WifiDnsAddress1**, **WifiDnsAddress2**, **WifiDnsSearchSuffix**—These settings are not used at this time.
- **WifiMacAddress**—The MAC address of the Wi-Fi Dongle. This is a read-only value.
- **WifiPassword**—Enter the password for the Wi-Fi network. Obtain the password from your network administrator. You must enter a password if you specify a Wi-Fi security mode. The password does not display after it is set.
- **WifiSecurityMode**—Set a security mode for the printer connection to the Wi-Fi network. If you specify a security mode, you also must enter a password. You can select from the following:
 - **None**—No security is used.
 - **WEP**—Use the WEP (Wired Equivalent Privacy) security protocol.
 - **WPA2**—Use the WPA2 (Wi-Fi Protected Access) security protocol.
- **WifiSSID**—Enter the SSID (Service Set Identifier) for the network. Obtain this value from your network administrator.

WifiModes



- The **WifiModes** option displays in the Printer Setting menu only when a Wi-Fi Dongle is installed in the printer.
- Set the **WifiModes** values after you enter the settings in **WifiNetworkStationSetup**. The printer attempts to start the network when **WifiModes** is set to Station and requires the values entered in **WifiNetworkStationSetup**.

The **WifiModes** settings allow you to enable or disable wireless communication. The printer supports the following Wi-Fi specifications:

- Wi-Fi types G (7 MB/s) and N (100 MB/s)
- Dual band 2GHz and 5GHz

Description	Default Value	Current Value (unit)
1)WifiMode	Disabled	Disabled
2) WifiRegDomain	US	US

Change the settings, and then click **Set Current** to apply the changes.

- **WifiMode**—Select **Station** to enable Wi-Fi communication.
- **WifiRegDomain**—Enter the country code for your region. Each country defines its own regulations for Wi-Fi connectivity. Entering the correct country code provides the optimum performance.

The following regions are supported:

Country	Symbol	Country	Symbol
Austria	AT	Italy	IT
Belgium	BE	Latvia	LV
Bulgaria	BG	Lithuania	LT
Canada	CA	Luxembourg	LU
Croatia	HR	Malta	MT
Cyprus	CY	Netherlands	NL
Czech Republic	CZ	Poland	PL
Denmark	DK	Portugal	PT
Estonia	EE	Romania	RO
Finland	FI	Slovakia	SK
France	FR	Slovenia	SI
Germany	DE	Spain	ES
Greece	GR	Sweden	SE
Hungary	HU	United Kingdom	GB
Ireland	IE	United States	US

The country codes are defined in ISO 3166-1.

Update Password

WebAdmin access-level personnel can specify to password protect Printer Manager and limit access to the advanced settings. Adding password protection is the preferred method of restricting access to Printer Manager. If no password is assigned, a password is not needed to log on to Printer Manager.

Description	Value
Choose Username to Update	WebAdmin
Current Password	
New Password	
Confirm New Password	

Do the following to change the password:

1. Select the access level for which you want to assign a password. The WebAdmin access level can update the WebAdmin and WebUser passwords.
2. Enter the current password. If a current password is not set, leave this field blank.
3. Enter the new password in the corresponding field. To remove a password, leave this field blank.
4. Enter the new password again to confirm it. Leave the field blank if you are removing the password.
5. Click **Update Password** to apply the changes.

HINTS & TIPS

- Passwords are hierarchical in the following order: WebService, WebAdmin, and WebUser. You can use a password that is higher in the hierarchy to log on to a specific role.
- Passwords may contain the following characters: a–z, A–Z, 0–9, +, and /.



Caution: Do not change the WebService password.

Set Job Queue State

Enter or select values prior to shipping the printer or system to or from repair facilities.



This setting is used primarily for financial printers. Contact your service provider for more information.

Field	Value	Description
Current Password		Enter the currently set password. Leave the field blank if no password has been set.
Next Password		Enter a new password. A blank value means that no password is required or leaves the current password unchanged, depending on the settings.
Confirm Next Password		Re-enter the same value used in the Next Password field.
State	<ul style="list-style-type: none">• Online• Suspend• Offline	<ul style="list-style-type: none">• StartJob succeeds if there is space in the queue.• StartJob succeeds if there is space in the queue and exceptionJob=true.• StartJob does not succeed under any circumstances.

Do the following to change the job queue state:

1. Enter the current password for the printer or system.
2. Enter a new password for the printer or system.
3. Re-enter the new password for verification.
4. Select a state:
 - **Online**—The printer performs normally.
 - **Suspend**—Deactivates the printer, but allows for some exception jobs.
 - **Offline**—Deactivates the printer for transportation.
5. Click **Set Job Queue State** to apply the changes.



To change an “Offline” printer to “Online,” you must enter the same password that was used to set it to “Offline.”

TroubleShooting Menu

The **TroubleShooting** menu for the WebAdmin access level contains settings and tools that help you isolate card production issues. Use the TroubleShooting options to run an SSA test when installing a magnetic stripe module, view and print the activity log, reset the log, reset counters, and reset the printer.

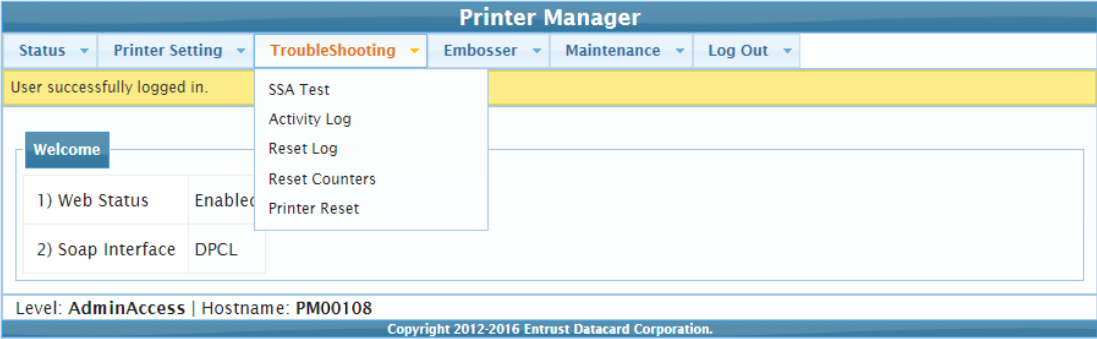

TroubleShooting Menu Option	Function	WebUser	WebAdmin
SSA Test	Calculate the location of the magnetic stripe start sentinel.	No	Select options and run the test
Activity Log	Display printer activity.	No	View
Reset Log	Reset the activity log.	No	Yes
Reset Counters	Reset card counters.	No	Yes
Printer Reset	Restart the printer.	No	Yes

SSA Test

The SSA Test calculates and stores the location of the magnetic stripe start sentinel. Use the test if you are adding a magnetic stripe module to the printer. Insert a card with a magnetic stripe into the printer, either in the input hopper or through the exception slot, and then click **Run**. The printer performs the test and ejects the card into the reject tray.

Description	Default Value	MagStripe Head
SSATest	1	1

- Select the magnetic stripe head to test.

Activity Log

The **Activity Log** displays information about printer activity for troubleshooting printer performance issues. It includes all actions and errors since last reset. Save and send the activity log to your service provider when you request service.

1. Click **Download** to save the activity log information.
2. Enter a location on your PC to save the file.
3. Save and send the activity log to your service provider when you request service.

Sample Data

18: 0d 17h 57m 10.479s [JOB____NOTICE] Film supply state is now PreRegisteringForPrinting

18: 0d 17h 57m 13.145s [JOB____NOTICE] Film supply state is now PreRegisteredForPrinting

18: 0d 17h 57m 13.145s [JOB____NOTICE] Ribbon supply state is now PreRegistered

Reset Log

The **Reset Log** option allows a WebAdmin access-level user to reset the Activity Log.

Click **Run** to reset the Activity Log.

Reset Counters

The **Reset Counters** option resets the Current Card counter functions in the printer. Life counters or total card counts cannot be reset.

Click **Run** to reset the counters.

Printer Reset

The **Printer Reset** option restarts the printer.

Click **Run** to restart the printer.

Embosser Menu



The Embosser menu displays only for a CE875 instant issuance system,

The Embosser menu allows WebAdmin access-level users to view and reset the embosser’s Audit Log.

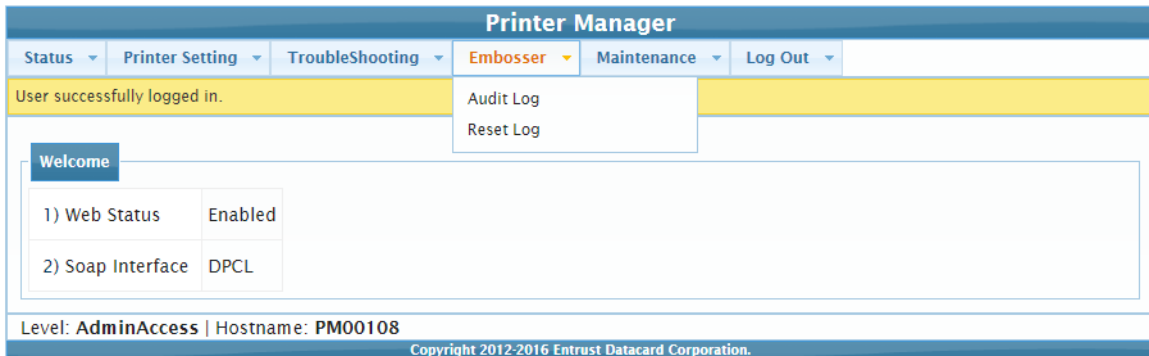

Embosser Menu Option	Function	WebUser	WebAdmin
Audit Log	Download the audit log.	No	View/Download
Reset Log	Reset the audit log.	No	Yes

Audit Log

The **Audit Log** page displays card and error reporting collected by the printer. This page acts as a general overview to track card production activity and problem history.

Click **Download** and specify a location to save the audit log.

The Audit Log data is saved as a .txt file that you can view or print.

Reset Log

The **Reset Log** option allows a WebAdmin access-level user to reset the Audit Log.

Click **Run** to reset the Audit Log.

The page reloads when the log reset is complete.

Maintenance Menu

The **Maintenance** menu allows WebUser and WebAdmin access-level users to run a cleaning card from Printer Manager. Additionally, the Maintenance menu provides the WebAdmin level with the rights to upload updates to the printer.

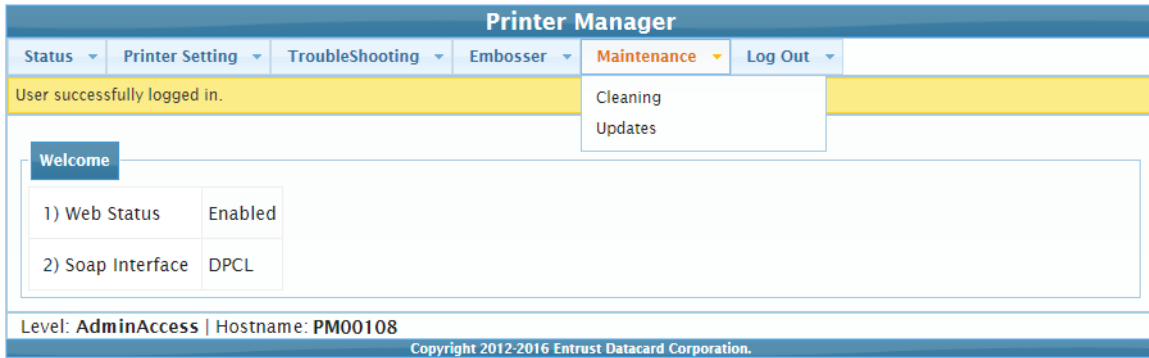

Maintenance Menu Option	Function	WebUser	WebAdmin
Cleaning	Clean the printer.	Run cleaning card	Run cleaning card
Updates	Update the printer settings.	No	Upload File

Cleaning

Cleans the printer using an isopropanol cleaning card.

Refer to the printer’s *User’s Guide* for complete information about cleaning the printer.

Clean the Printer

1. Unlock the printer.
2. Remove the ink ribbon and retransfer film cartridges, and the cleaning sleeve from the printer.
3. Remove any blank card stock from the input hopper.



If you are cleaning a printer with a multi-hopper, you do not need to remove cards from the input hopper cartridges.

4. Close and lock the printer.

5. Place the isopropanol cleaning card in the card input hopper. If you are cleaning a printer with a multi-hopper, insert the cleaning card in the exception slide.
6. Select **Maintenance > Cleaning**.
7. Select **Clean Printer**.
8. Click **Run** to start the cleaning process. Press the USER button on the printer when the message “172: Insert cleaning card” displays on the LCD panel.

The printer picks the cleaning card and moves it through the printer several times, and ejects it in the output hopper or places it in the card reject tray.



If you are cleaning a CE875 system, the cleaning card moves into the embosser after cleaning the printer and cleans the card entry area and embosser rollers. The cleaning card is placed in the embosser reject tray. Open the embosser to remove the cleaning card.

9. Unlock the printer
10. Remove the used cleaning card.
11. Replace the cards in the input hopper.
12. Install a new cleaning sleeve. Refer to [“Install the Cleaning Sleeve”](#) on page 24.
13. Replace the ink ribbon and retransfer film cartridges and close the printer access door. Lock the printer.

Updates

The **Updates** option allows a WebAdmin access-level user to send an external settings file to the printer.

To upload a settings file:

1. Click **Browse** and select the file to upload.
2. Click **Upload File**.

Log Out Menu

Use the **Log Out** option to end the current Printer Manager session and return to the Printer Manager Log In page. For security, close the browser window after you log out.



Log Out Menu Option	Function	WebUser	WebAdmin
Log Out	Log out and return to the Log In page.	Yes	Yes



Chapter 4: Supplies and Parts

4

This chapter describes the recommended supplies and replacement parts to use with your printer.

This chapter includes the following information:

- [Printer Supplies](#) on page 112
- [Cards](#) on page 114
- [Cleaning Supplies](#) on page 116
- [Replacement Parts](#) on page 117
- [Optional Equipment](#) on page 117
- [Cables and Power Supplies](#) on page 118

If you have a CE875 system with an embosser, refer to [Appendix A: "CE875 Instant Issuance System"](#) for information about embosser supplies and replacement parts.

Printer Supplies

Use the following information to order ink ribbon and retransfer film.

Ink Ribbon

Color ink ribbons are designed for full-color card printing. Ink ribbon kits are available from your dealer. Kits include the ink ribbon, an isopropanol cleaning card, and a replaceable cleaning sleeve. For best results, always clean the printer and replace the cleaning sleeve with each new ink ribbon. Refer to the printer's *User's Guide* for complete information about cleaning the printer.

The following ink ribbons are available.

Ribbon Type	Part No.	Panel Sets/Roll	Description
CMYKP-KPi	513382-305	500	Full-color and monochrome printing on the front of the card, monochrome with non-printing inhibitor area on the back.
CMYKP	513382-301	1000	Full-color and monochrome printing on one side of the card.

Retransfer Film

The following retransfer film is available.

Material	Part No.	Description
Retransfer film	513402-101	Prints up to 1500 images
Retransfer film	513402-102	Prints up to 1000 images

Supply Storage Guidelines

Follow these guidelines when storing ink ribbon or retransfer film rolls:

- Store supplies in their original packaging until you are ready to use them.
- Select a location away from direct sunlight, with a temperature between 50°F and 80°F (10°C and 27°C) with a maximum of 30% to 70% relative humidity.
- Do not store supplies in direct sunlight or high humidity locations.
- Do not store supplies near heating ducts or blowers.
- The supplies maintain their quality for about one year. For optimal card quality, purchase and store quantities that you can use in less than a year.
- The ink ribbon, retransfer film, and card stock might require secure storage and tracking. Follow your policy for storing and tracking the supplies used to make cards.
- Supply rolls must be at room temperature when they are installed in the printer and used. If supplies are stored in a cooler environment than the printer, allow supplies to reach room temperature before using them.
- If the printer will not be used for an extended period of time, remove supplies from the printer and store them.

Cards

For best results, use high-quality cards that meet the following specifications and recommendations.

Card Size

Use ISO ID-1 (also called CR80) size cards with the following dimensions:

Length	3.37 inches	85.60 mm
Width	2.125 inches	53.98 mm
Thickness	0.030 inch	0.762 mm

Actual card thickness can vary by up to ten percent from the sizes listed. The card bow must be less than the thickness of the card.

Card Material

Use cards made from the following materials:

- PVC
- Polycarbonates
- PET
- PET-G

Cards can have a magnetic stripe and signature panel on the back side of the card, and a smart card chip on the front side.

Card Surface Finish

Cards must have a smooth surface finish for proper retransfer film quality. Cards with a polished or satin finish typically work the best. Print quality may suffer on cards with a matte finish.

Card Irregularities

The heated roller must not lose close contact with the card and retransfer film for proper transfer to the card to take place. Large surface irregularities on a card (such as, bumps, pits, burrs, and so on) cause loss of close contact, and result in print voids.

Even the highest quality manufacturing materials and processes can yield cards with surface irregularities that are large enough to cause print voids. Many surface irregularities are unavoidable (for example, magnetic stripe edges, signature panel edges). Your site must work with your chosen card manufacturer to determine the number and location of unacceptable surface irregularities in any batch of cards.

Card Die Cutting

Cards printed on retransfer printers can have a small, sometimes noticeable, void area (a small white border) around the perimeter of the card where the printing does not transfer to the card. The orientation of the cards during the die cutting manufacturing process has an effect on the size of the non-transferred perimeter.

To obtain the smallest void area, place the image on the card side where the die cutter exited the plastic during the manufacturing process (the burr side).

Work with your card supplier to manage the card manufacturing and packaging to ensure the correct orientation of the die-cut cards before shipment. Operators also must be aware that they need to load the cards in the correct orientation into the card printer.



This is an issue only when using cards with blank white surfaces on both sides since the burr side is not obvious after the card is removed from the card tray. Trays of blank white cards should be labeled to indicate the burr side.

For additional information about card stock guidelines, refer to the *Card Stock Requirements Guide*.

Card Handling

These guidelines apply to unprinted cards.

- Debris or particles on blank card stock can reduce card quality and damage the system.
- Grease or oils, such as oils from your fingers, also reduce card quality. Keep cards completely clean. Do not touch the print surface of a card with your fingers or hands. Handle blank card stock by the edges only, or wear gloves.
- Do not use a rubber band to bind blank cards together.
- If you drop a card on the floor, clean it using a lint-free cloth before using it in the system. Do not use solvents to clean the card.

Card Storage

These guidelines apply to both blank card stock and processed cards.

- Use cards that are at room temperature. If cards are stored in a cooler environment than the printer, allow them to reach room temperature before using them.
- Stack cards so that they will not shift and rub against each other.
- Make sure that the magnetic stripe on one card does not come in contact with the magnetic stripe on another card.
- Make sure that cards with magnetic stripes are stored away from magnetic objects.
- Store cards in a cool, dry, and dark place. Excessive light can cause yellowing of cards on exposed edges.
- Store cards in their original packaging.

Cleaning Supplies

For best results, keep additional cleaning supplies available.

The following cleaning supplies are available:

Supply	Part No.	Description
Isopropanol cleaning cards	552141-002	Pack of 10 double-sided, isopropanol cleaning cards used to clean the printer card track and transport rollers.
Adhesive cleaning cards	524405-001	Pack of 10 adhesive cleaning cards used to clean the printer card track, transport rollers, and printhead cam rollers,.
Cleaning sleeves	569946-001	Pack of 5 adhesive cleaning sleeves.
Cleaning swabs	507377-001	Pack of 5 cleaning swabs for cleaning debris and dust from the printhead and from hard-to-reach internal areas of the printer.
Lapping sticks	510108-001	Used to clean the printhead.
Lapping stick support	529147-001	Support tool used to guide the lapping stick and cleaning swab when cleaning the printhead.
Card inspection gloves	812335-001	Nylon gloves for card handling, 12 pairs/pack.

Replacement Parts

The following replacement parts are available for use with the printer.

Ink Ribbon Cartridge

The blue ink ribbon cartridge holds the print ribbon.

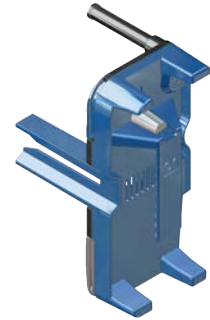

Retransfer Film Cartridge

The yellow retransfer film cartridge holds the retransfer film.

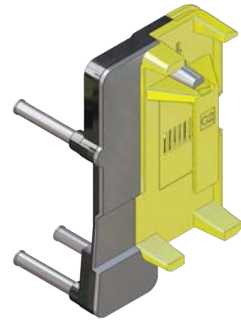

Cleaning Spindle

The cleaning spindle holds the replaceable cleaning sleeve.

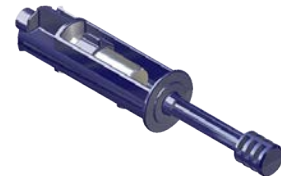

Optional Equipment

Large Output Hopper

The printer can be used with a large output hopper, which holds about 125 cards. You can replace the smaller, standard hopper with the large hopper without using tools.



The large output hopper cannot be used with the CE875 instant issuance system.

Cable Lock

The printer and embosser can be secured with an optional cable lock. Obtain the lock from your authorized dealer, because it includes an added security plate that is inserted into the printer.

Cables and Power Supplies

The following cables and power supplies are used by the printer.

Data Cable

The Ethernet data cable connects the printer to the network.

Use a standard Ethernet network cable, either a Cat 5 or Cat 5e cable, to connect the printer to a network port.



Ethernet cables are not available from Entrust Datacard. You can purchase a cable from a third-party supplier.

Printer Power Supply

The printer power supply is rated as follows:

- Input: 110–240V, 50–60Hz, 1.5A
- Output: 24V, 6.6A, 160W

It is self-adjusting within the rated input voltage.

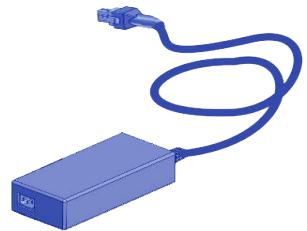

Power Cords

The power cords connect the power supplies for the printer, and any attached component, to the facility power. Be sure to use power cords that ground to the facility power source.

The following country-specific power cords are available:

- USA Power cord
- Australia power cord
- Brazil power cord
- China power cord
- Denmark power cord
- European power cord
- India power cord
- Israel power cord
- Italy power cord
- Japan power cord
- South Africa power cord
- Swiss power cord
- United Kingdom power cord





Appendix A: CE875 Instant Issuance System



This appendix provides information about setting up the CE875 instant issuance system.

Introduction

The CE875 system consists of a card printer and the CEM embosser. The CE875 system can print cards and then emboss and indent characters on the card. The embosser creates the raised lettering and numbering on the front and back of most financial or debit cards.

The embosser can contain an embossing wheel and topping and indent ribbon cartridges. The embossing wheel can have up to 75 punch and die (emboss) or punch and anvil (indent) pairs. A second wheel option allows for up to 75 additional emboss characters. Multiple font choices and a variety of special characters are available for the embossing wheel.

Single-Hopper System

Multi-Hopper System

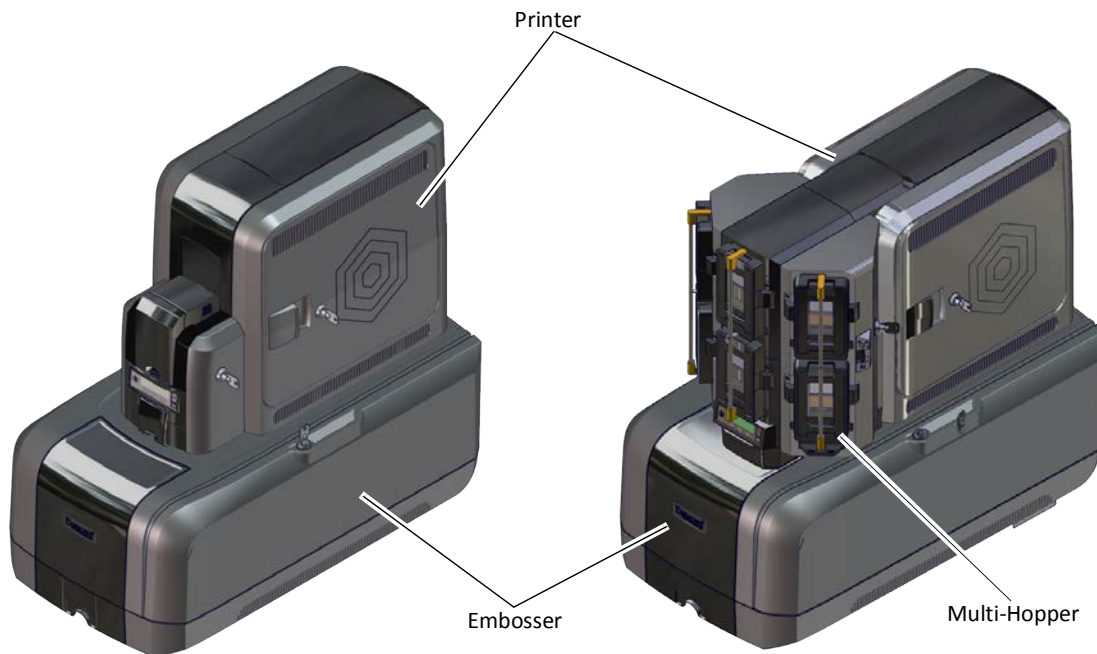

Site Requirements

Provide space for the system and for clearance around the system. Use the following system dimensions and clearance area.

System Dimensions

The external system dimensions are shown in the following illustrations.

Single-Hopper System

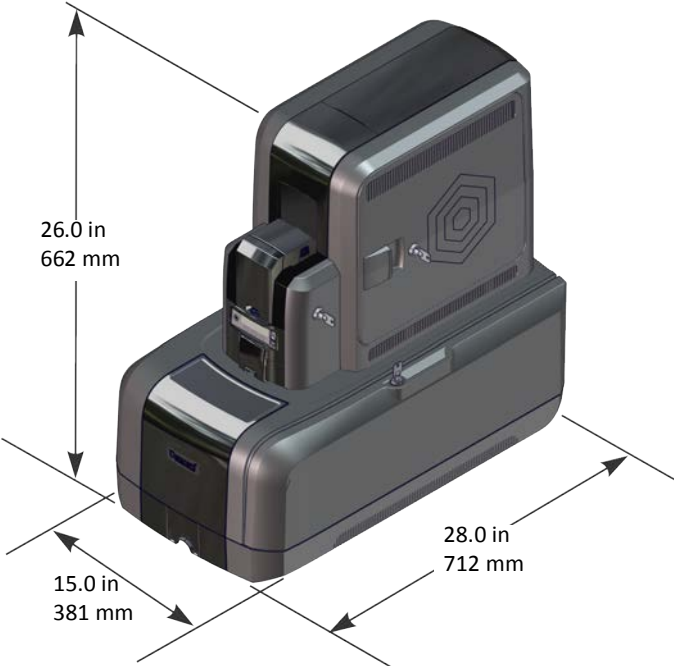

Multi-Hopper System

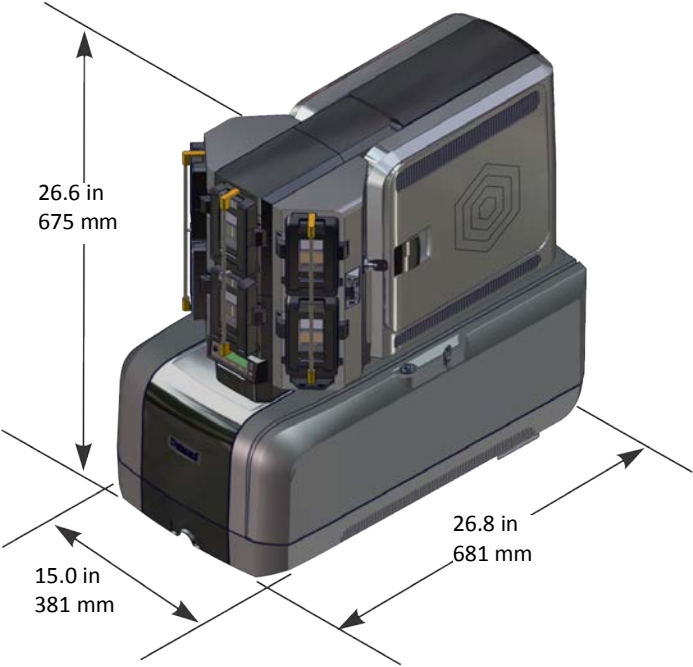

Clearance Requirements

The following measurements show the system dimensions when the system access doors are open and the power cord is connected. We recommend that you provide at least 3 inches (76.2 mm) of additional clearance around the system to maintain access to the power cords and data cables, and to allow you to load and remove cards and supplies.

Single-Hopper System

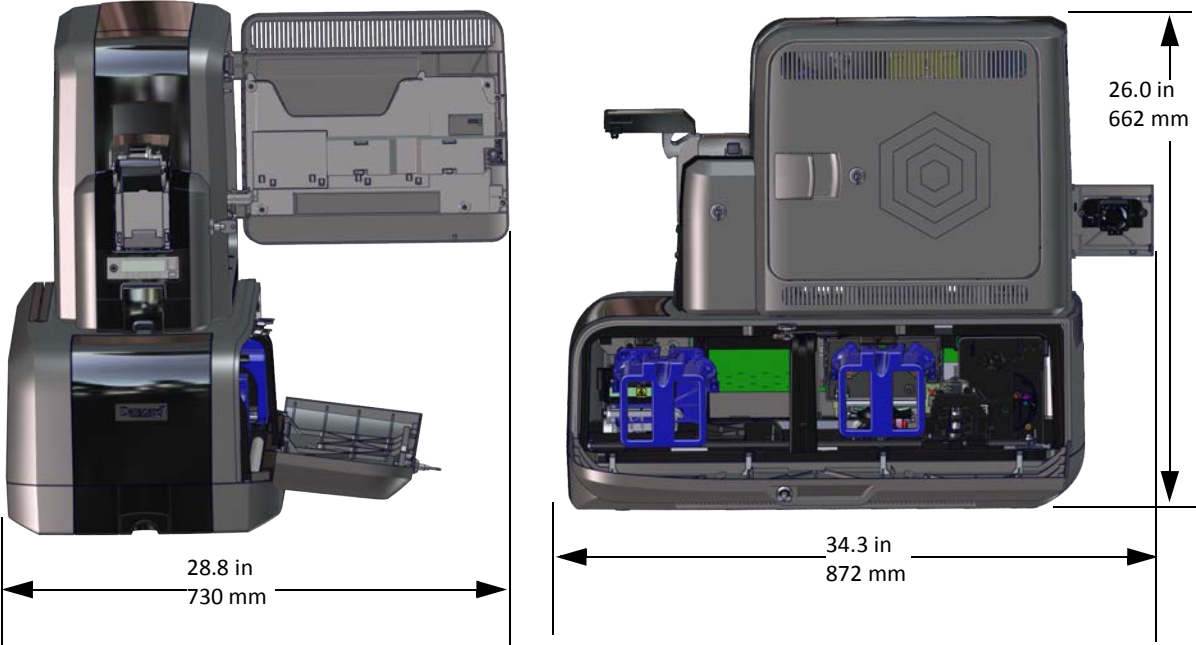

Multi-Hopper System

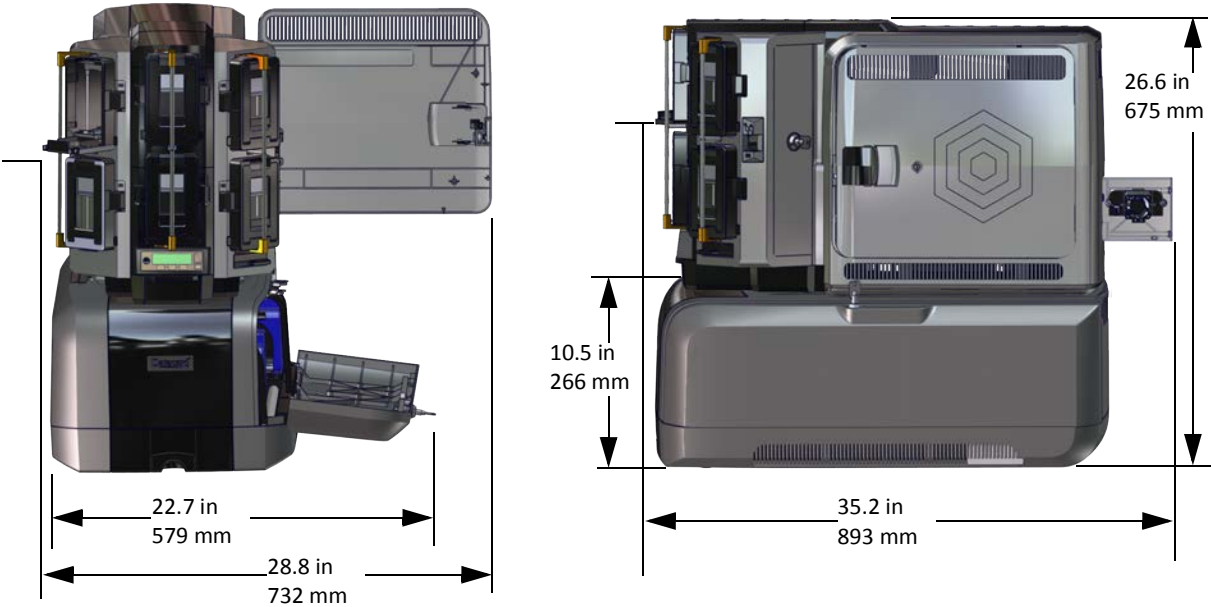

Electrical Requirements

The power supply is rated as follows:

System Component	Electrical Requirements	
	Input	Output
Printer	85–230VAC/47-63 Hz/1.2Amp	24V/6.6Amp/160W
Embosser	110-240V/50-60Hz/3.5Amp	24V/10.42Amp/250W

The power supply detects the input voltage and works within the stated range.

Unpack the Embosser

Remove the embosser from its shipping carton.



Refer to [“Unpack the Printer”](#) on [page 9](#) for information about how to prepare the printer.

1. Open the shipping carton and remove the accessories box.

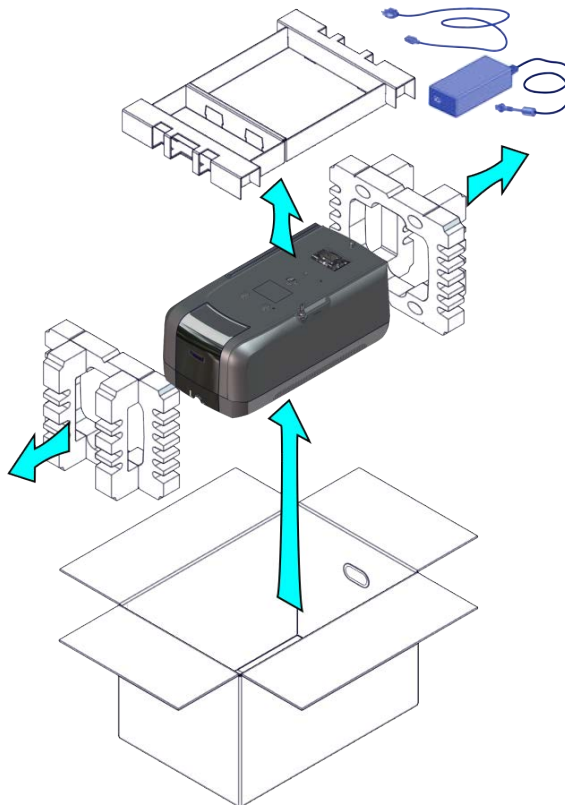

2. Lift the embosser from the carton and remove the foam end caps.
3. Place the embosser on a surface that meets the requirements specified in [“Site Requirements”](#) on [page A-2](#).



Save the shipping cartons and packing materials. They are required if you need to store, move, or return the embosser for service.

Remove Shipping Items

The embosser is shipped with inserts that secure internal components during transport. Remove these items before proceeding with setup.

1. Unlock and open the embosser supplies access door.
2. Remove the indent ribbon and topping foil cartridges.
3. Remove the foam “T” and block inserts used to secure the topping and transport mechanisms during shipping. Save the inserts in case you need to repack the embosser for transport.

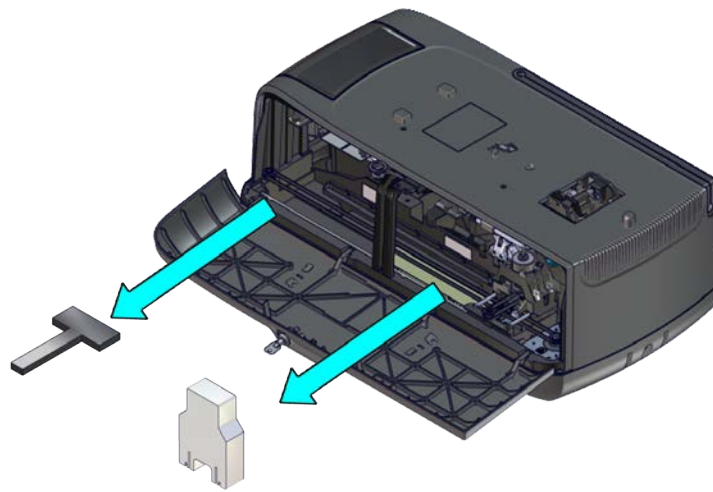

4. If you plan to secure the embosser to a worktable, continue with [“Secure the Embosser”](#).

Secure the Embosser



This procedure is optional. Contact your system administrator for requirements.

You can secure the embosser using one of the following:

- The bolt-down openings in the bottom of the embosser enclosure
- An optional cable lock

Use the Embosser Bolt-Down Openings

The embosser includes bolt-down openings that you can use to secure the system to a mounting surface.

1. Open the embosser supplies access door.
2. If installed, remove the topping foil and indent ribbon cartridges and set them aside.
3. Bolt the embosser to the work surface.

You need the following supplies:

- Two 1/4-inch (6 mm) bolts.
The length of the bolts depends on the thickness of the mounting surface. Bolt length minimum is surface thickness + 3/4 inch (20 mm). Bolt length maximum is surface thickness + 1 1/4 inch (30 mm).
- Two 5/8-inch (18 mm) outer diameter washers.
- Two 1/4-inch (6 mm) nuts. Lock nuts are recommended.

- a. Drill holes in the mounting surface following the dimensions and requirements shown on the following page.
- b. Insert the bolts.

Note: Make sure that you insert the bolts inside the embosser pointing down through the mounting surface.

- i. Insert the bolts into the mounting holes inside the embosser.
 - ii. Align the bolts with the holes in the table or mounting surface.
 - iii. Place a flat washer on each of the bolts, under the mounting surface.
- c. Secure the embosser using washers and nuts under the mounting surface.

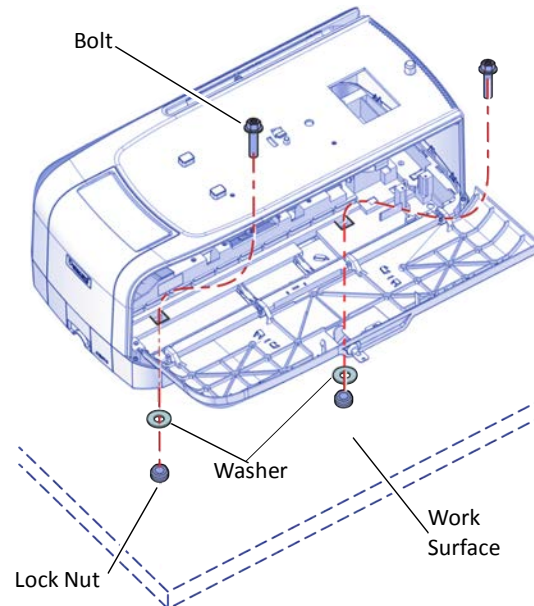
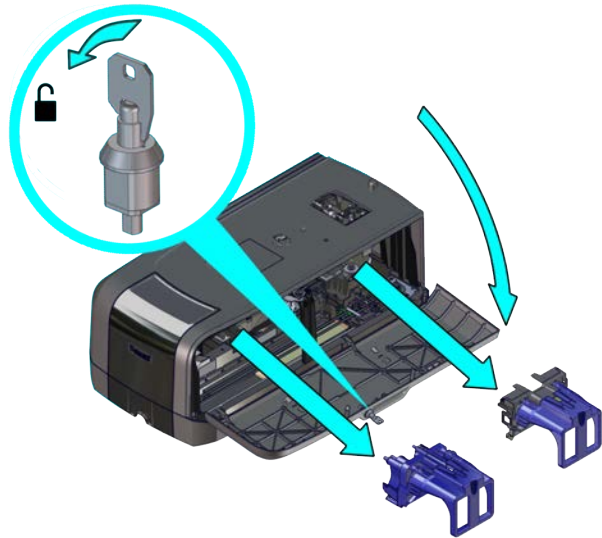

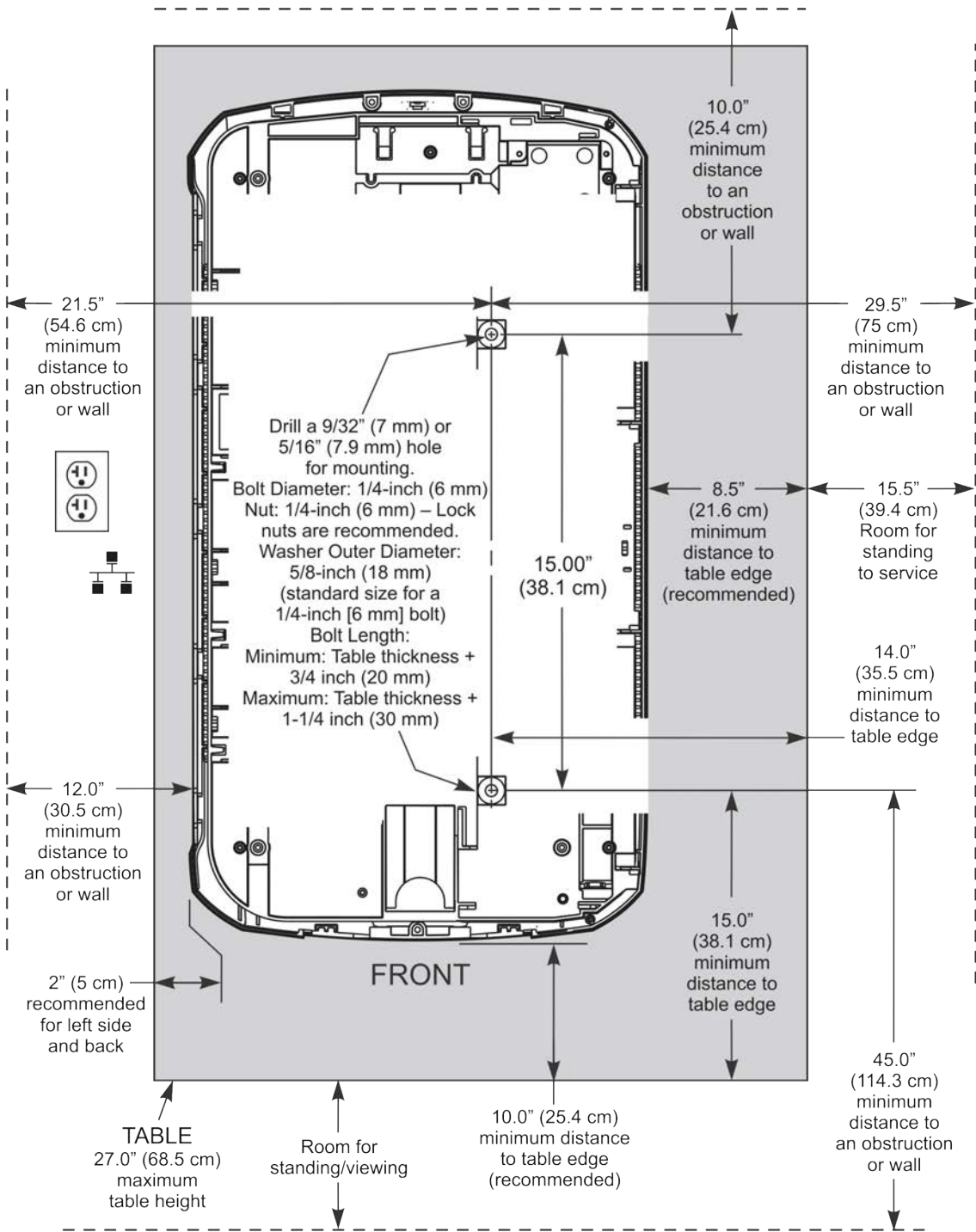

Use the Embosser Cable Lock

You also can secure the embosser using the optional cable lock.

1. Locate the security plate receptacle at the back of the embosser.
2. Insert the security plate vertically into the receptacle from below the embosser with the open end toward the embosser.
3. Insert the T-bar of the cable lock through the opening into the security plate.
4. Follow the instructions included with the cable lock to complete the installation.



Assemble the Printer and Embosser

1. Locate the interconnect cable in the cable routing area of the embosser and make sure that it remains accessible.
2. Slide the printer locking lever in the embosser to the left to place the mounting lock in the unlocked position.
3. Lift the printer over the embosser and align the pins on the embosser with the holes on the underside of the printer.
4. Press down on the printer carefully, but firmly, to position it.
5. Push the printer locking lever to the right to lock the printer onto the embosser. Make sure that the printer is securely locked to the embosser.

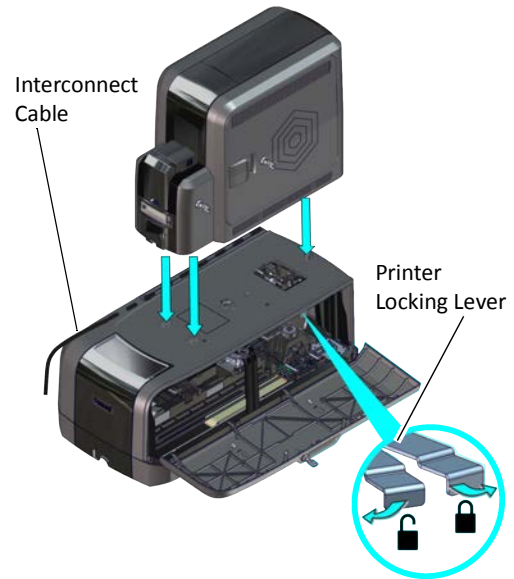

6. Connect the interconnect cable from the embosser to the data port on the printer.

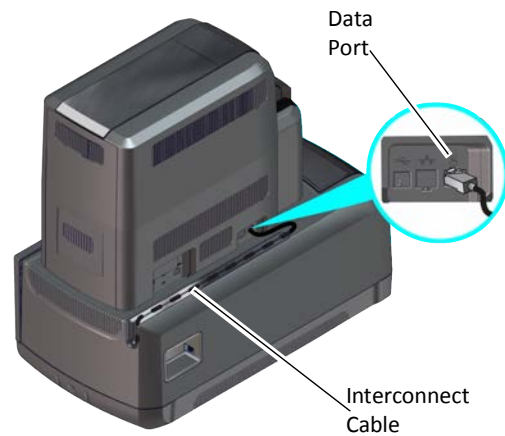

Connect the Power Cords

1. Connect the printer power cord to the printer and the printer power supply.
2. Plug the power supply cord into the power outlet.

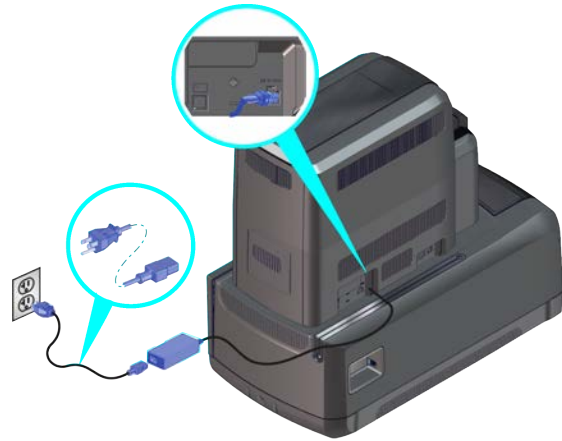

3. Connect the embosser power cord to the embosser and to the embosser power supply.
4. Plug the power supply cord into the power outlet.

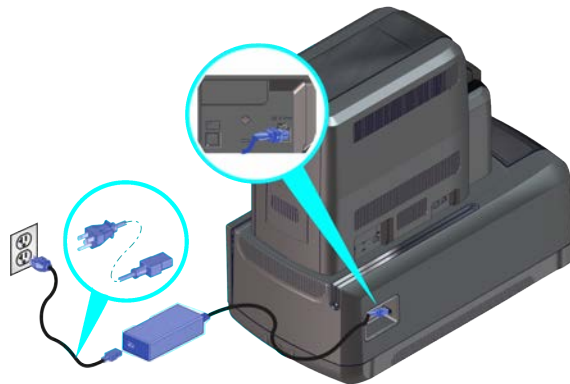

Connect the System to the Network

1. Connect one end of the Ethernet cable to the network connection port on the printer.
2. Connect the other end to a network port.

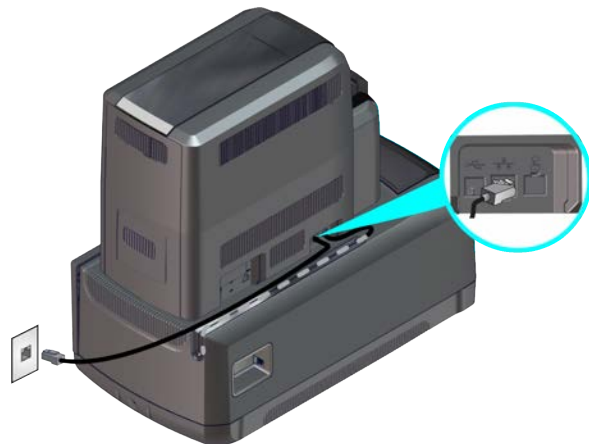

Load Embosser Supplies

Embossing supplies include topping foil and indent ribbon. The topping foil is applied to the embossed characters and can be applied to up to five lines of characters. The indent ribbon is used to apply black or white color to a single line of indented characters.

If the embosser supplies are preloaded into their cartridges, install the cartridges into the embosser.



The topping foil and indent ribbon cartridges are not interchangeable. They fit only into the designated cartridge areas.

Load the Indent Ribbon Cartridge

1. Prepare the indent ribbon cartridge and indent roll.

- a. Open the embosser supplies access door and remove the indent ribbon cartridge from the embosser, if necessary. The indent ribbon cartridge is on the right as you face the open embosser.
- b. Place the indent ribbon cartridge on a flat surface with the spindles facing up.
- c. Remove the new indent roll from its package.

IMPORTANT! Do not separate the silver take-up spool away from the blue supply spool.



2. Secure the blue supply spool into the spindle.

- a. Match the keyed pattern of the supply spool hub with the left side spindle.
- b. Push the supply spool into the spindle until it clicks securely into place.

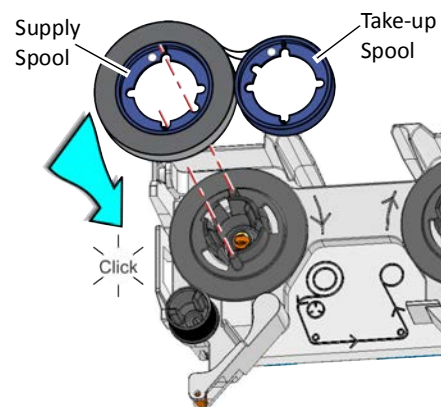

3. Prepare the ribbon for routing.
 - a. Roll up one full turn of indent ribbon on the silver take-up spool.
 - b. Roll out a slack length of indent ribbon from the supply spool.

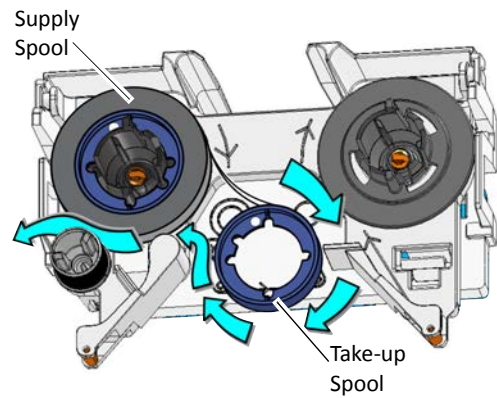

4. Route the ribbon around the rollers on the indent ribbon cartridge.

IMPORTANT! Do not twist the ribbon while routing.

5. Secure the take-up spool into the spindle.
 - a. Match the keyed pattern of the take-up spool hub with the right-side spindle.
 - b. Push the take-up spool into the spindle until it clicks securely into place.

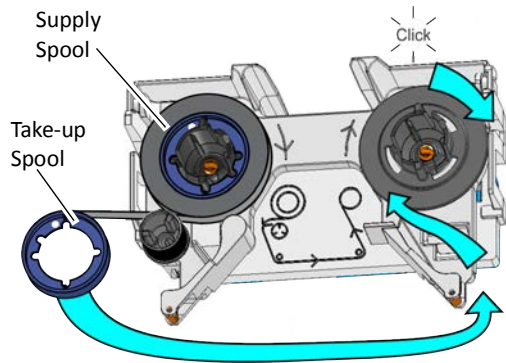

6. Turn the take-up spool one full turn clockwise to take up ribbon slack.
7. Replace the indent ribbon cartridge.

- a. Hold the cartridge by its handle.
- b. Align the cartridge with the guides inside the embosser.
- c. Slide the cartridge in until it clicks and stops.

8. Continue with [“Load the Topping Foil Cartridge”](#) on page A-15.



Load the Topping Foil Cartridge

1. Prepare the topping foil cartridge and topping roll.

- a. Remove the topping foil cartridge from the embosser, if necessary. The topping foil cartridge is on the left as you face the open embosser.
- b. Place the topping foil cartridge on a flat surface with the spindles facing up.
- c. Remove the new topping foil from its package.



2. Secure the supply spool into the spindle.

- a. Match the keyed pattern of the blue supply spool hub with the right-side spindle.
- b. Push the supply spool into the spindle until it clicks securely into place.

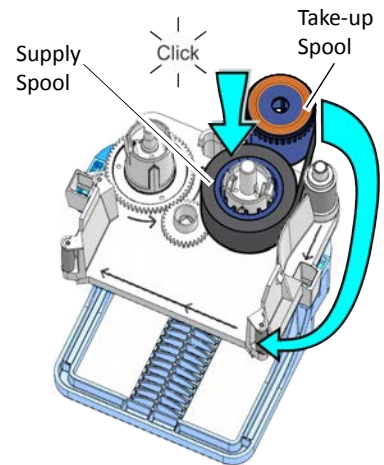

3. Roll out and route the foil around the rollers on the topping foil cartridge.

4. Secure the silver take-up spool into the spindle.

- a. Match the keyed pattern of the take-up spool hub with the left-side spindle.
- b. Push the take-up spool into the spindle until it clicks securely into place.

5. Turn the take-up spool one full turn counterclockwise to take up foil slack.

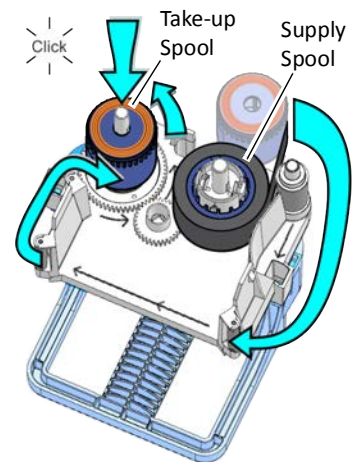

6. Replace the topping foil cartridge.
 - a. Hold the cartridge by its handle.
 - b. Align the top of the cartridge with the guides inside the embosser.
 - c. Slide the cartridge in until it clicks and stops.
7. Close and lock the embosser supplies access door.



Power On the System

Press the power button on the front panel of the printer to power on the system. The printer and embosser perform internal checks and initialize supplies.

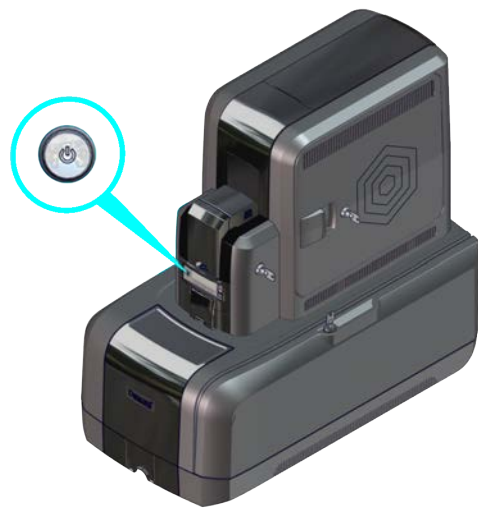

The first time you power on the system, you may need to enter an activation code. Refer to [“Activate the Printer”](#) on [page 17](#) for complete information.

Embosser Supplies

The following supplies are available for the embosser.

Indent Ribbon

The following indent ribbons are available. Cards per roll are dependent on the number of indent characters per card, the font size, and the print length.

Indent Ribbon	Part No.	Description
Ribbon, Black	504461-001	Up to 900, 7-character cards per roll
Ribbon, White	504461-002	Yield can vary depending on font size and the number of characters.

Topping Foil

The following topping foils are available:

Topping Foil	Part No.	Description
Foil, Silver	504139-013	Up to 500 cards per roll
Foil, Black	504139-002	
Foil, Gold	504139-003	
Foil, Dark Blue	504139-001	
Foil, White	504139-028	
Foil, Copper	504139-033	

Embosser Supply Storage Guidelines

- Store supplies in the original package until you load them into the embosser.
- Keep the original packaging closed.
- The indent ribbon and topping foil maintain their quality for about one year. For optimum card quality, purchase and store quantities that can be used within one year.
- The indent ribbon, topping foil, and card stock might require secure storage and tracking. Follow your organization's policy for storing and tracking the supplies used to make cards.
- Choose a location away from direct sunlight, with a temperature between 32° and 77°F (0° and 25°C). A humidity range from 40% to 60% non-condensing is recommended.
- Keep supply rolls at room temperature when installed in the embosser. If supplies are stored in an environment that is cooler than the system environment, allow supplies to reach room temperature before using them.
- Install supply rolls into the system within 24 hours of being unpacked.
- If the system will not be used for an extended period, remove supplies from the embosser and store them with new supplies.
- Supplies for the system may be an audited item. Check with your system administrator to follow company policies regarding financial instant issuance.

Embosser Replacement Parts

The following replacement parts are available for the embosser.

Indent Ribbon Cartridge

The indent ribbon cartridge holds the indent ribbon.

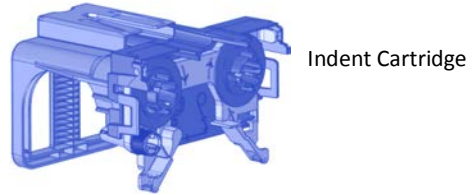

Topping Foil Cartridge

The topping foil cartridge holds the topping foil used on the embossed characters.

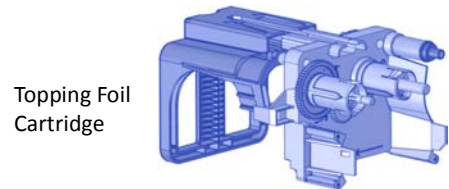

Embosser Power Supply

The embosser power supply is rated as follows:

- Input: 110–240V, 50–60Hz, 3.5A
- Output: 24V, 10.42A, 250W

It is self-adjusting within the rated input voltage.

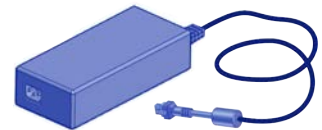

Power Cords

Refer to “[Power Cords](#)” on [page 119](#) for a list of available power cords.

