



ENTRUST

Quick Install Guide

CE870™ Instant Issuance System

December 2020
527261-001, Rev L

Refer to your printer's *Installation and Administrator's Guide*, found on the *Owner's Library* CD, for detailed installation instructions.

1. Select a Location for the Printer

- Install the printer in a location that is clean and well ventilated, free of vibration or shock.
- For venting and clearance, choose an area that has the following measurements:
 - **Single-Hopper System:** 27 inches (686 mm) wide, 31 inches (788 mm) deep, and at least 27.4 inches (696 mm) high.
 - **Multi-Hopper System:** 28 inches (711 mm) wide, 41 inches (1041 mm) deep, and at least 30 inches (762 mm) high.

Refer to the printer's *Installation and Administrator's Guide* for complete site requirements.

- Do not install the printer in direct sunlight.
- Install the system in a secure location.
- Install the system in a location that has access to two AC outlets and a network port.

2. Unpack the System

Remove the printer and the embosser from their shipping cartons.

Single-Hopper Printer

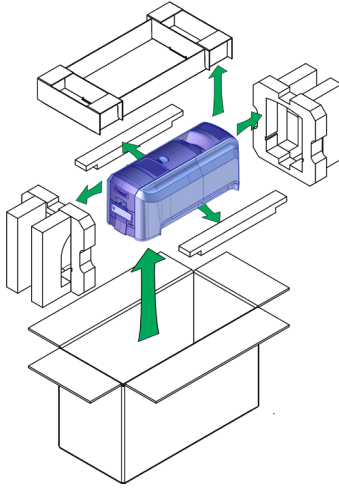

Multi-Hopper Printer

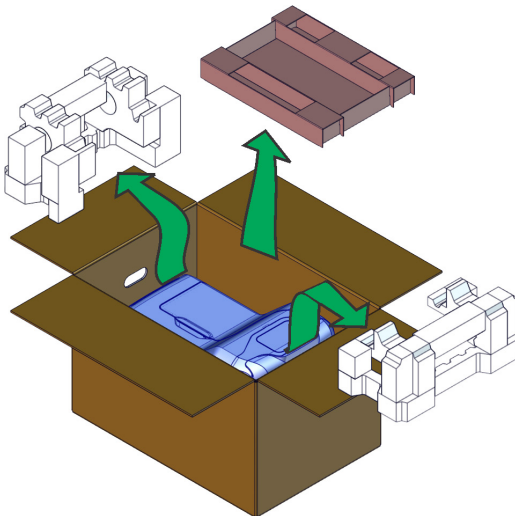

Embosser

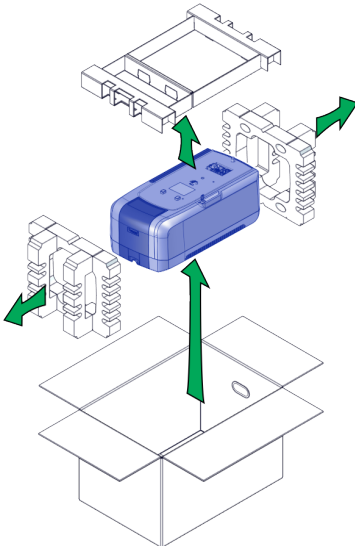

3. Remove Shipping Items

- (Multi-hopper printer only): Unlock the printer and open the printer supplies access door and the multi-hopper cover.
- Remove the packing material inserted behind the hopper and inside the cover.

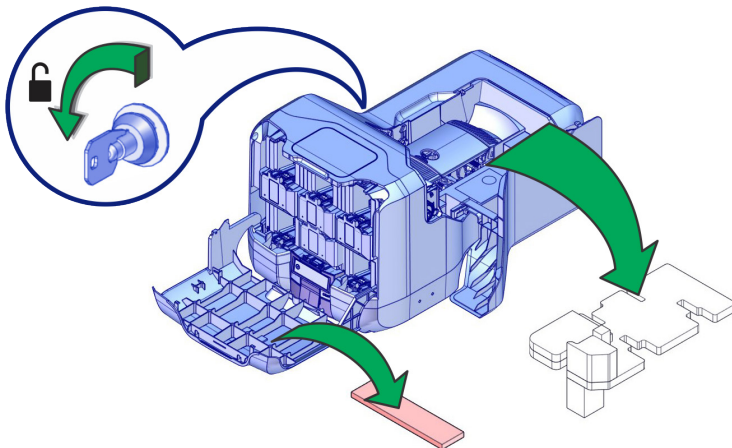

- c. Unlock the embosser and remove the indent ribbon and topping foil cartridges.

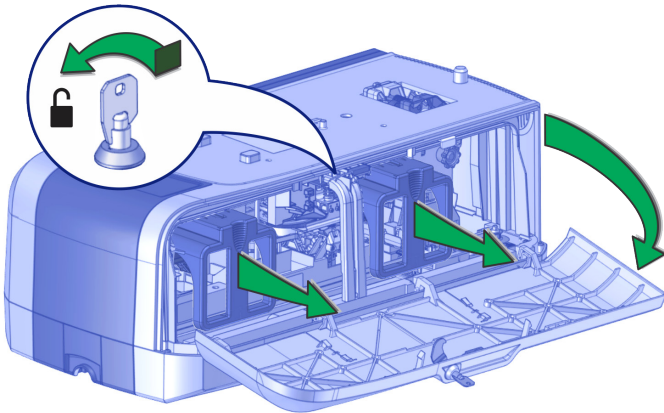

- d. Remove the foam “T” and block inserts used to secure the embosser topping and transport mechanisms during shipping.

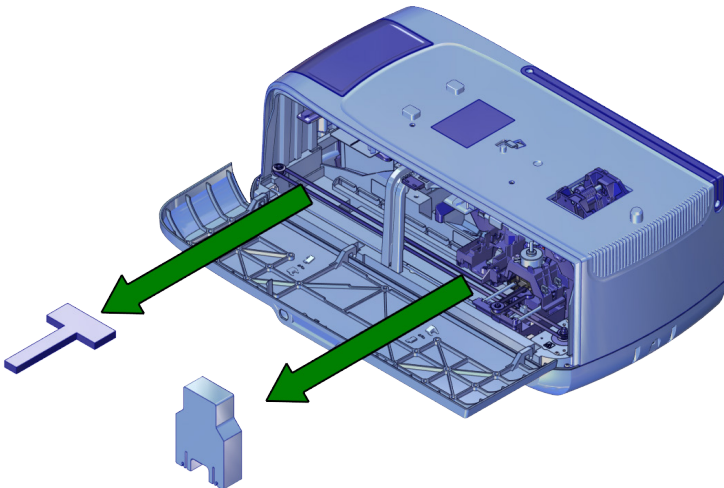

4. Secure the System

- a. Secure the embosser to the work surface (if required). Refer to the printer's *Installation and Administrator's Guide* for detailed installation instructions and measurements.

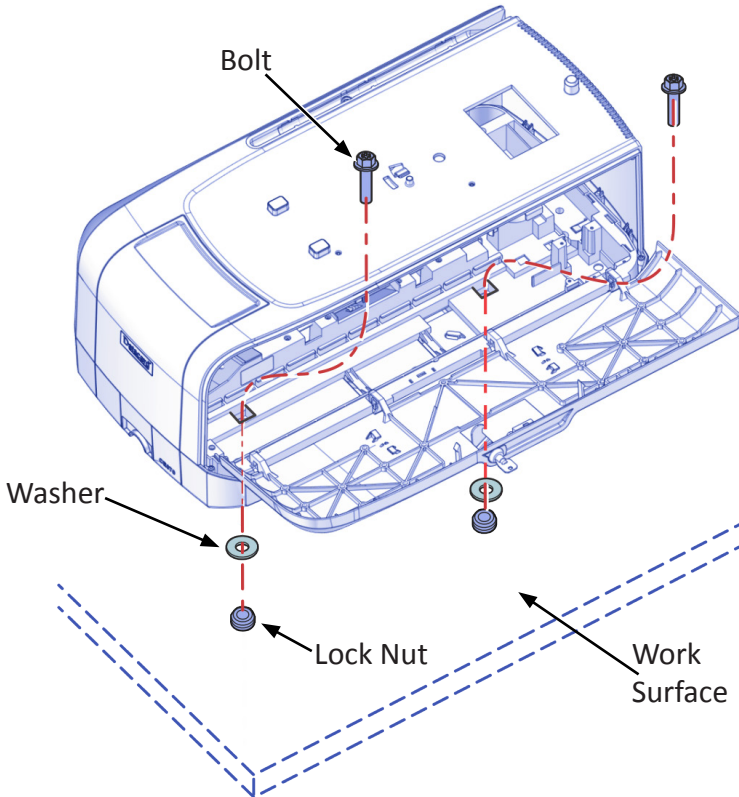

5. Assemble the Printer and Embosser

- a. Locate the interconnect cable in the cable routing area of the embosser, and make sure that it remains accessible.
- b. Slide the printer locking lever inside the embosser to the left to move the mounting lock to the unlocked position.

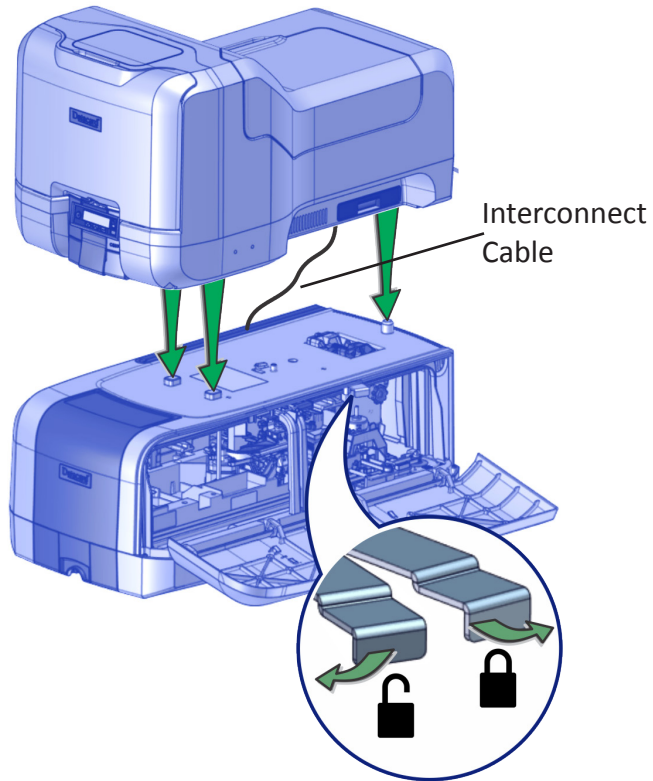

- c. Lift the printer over the embosser and align the pins on the embosser with the holes on the underside of the printer.

CE870 Instant Issuance System

- d. Press down carefully, but firmly, on the printer to position it.
- e. Push the printer locking lever to the right to lock the printer to the embosser. Make sure that the printer is locked securely to the embosser.
- f. Connect the interconnect cable from the embosser to the lower data port on the printer.

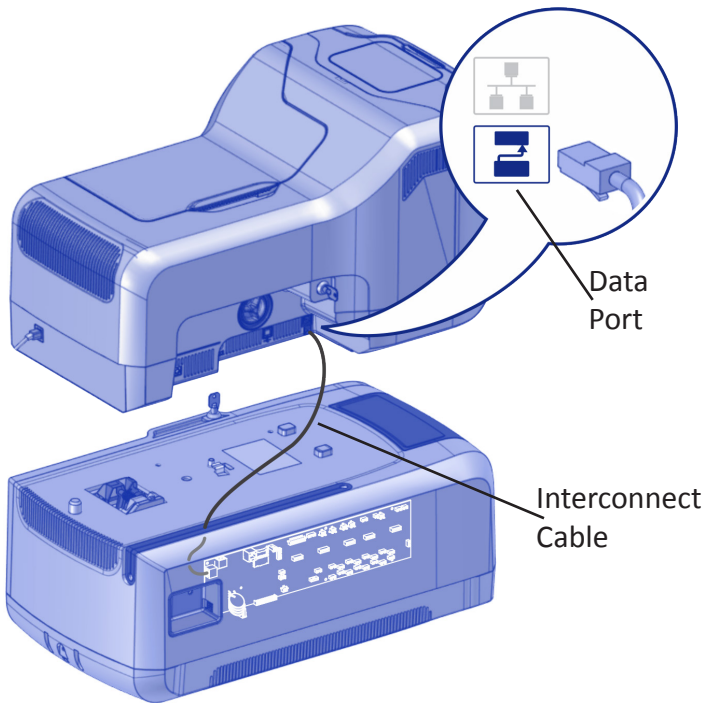

6. Connect the Power Cords

- Connect the printer power cord into the printer and into the power supply.
- Connect the power supply cord into the power outlet.

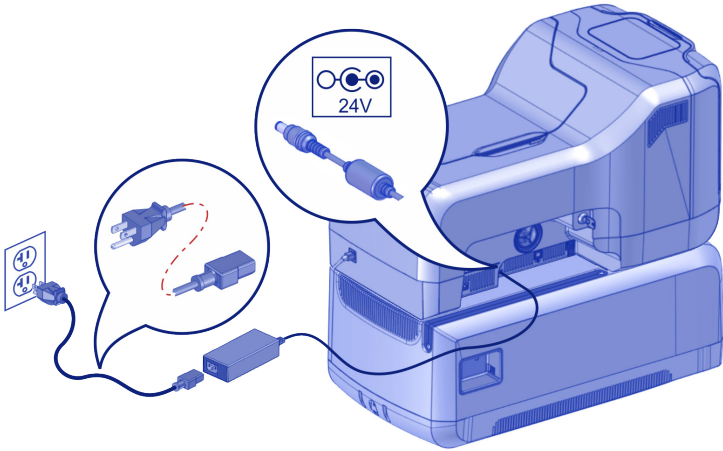

- Connect the embosser power cord into the embosser and power supply.
- Connect the power supply cord into the power outlet.

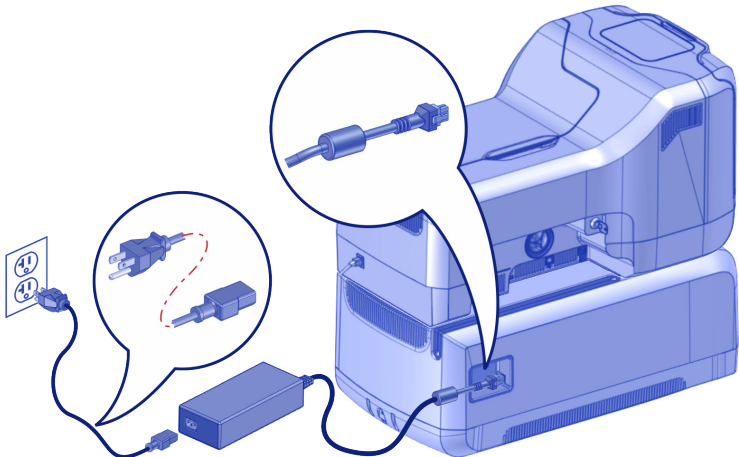

7. Load Supplies

Supplies are ordered separately.

- a. Load the indent ribbon onto the cartridge.

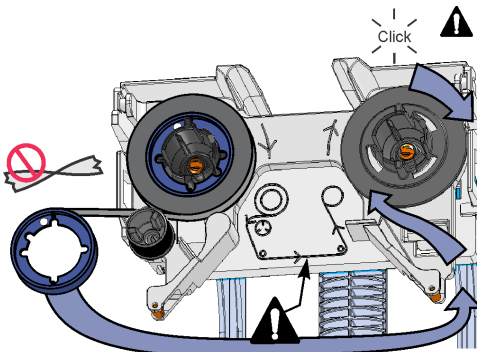
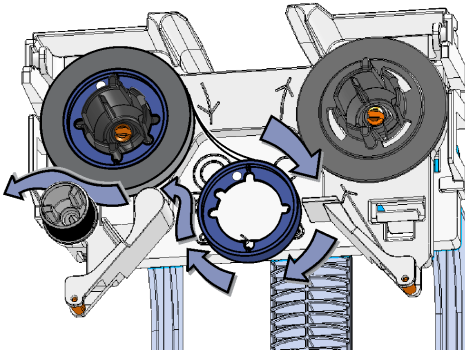
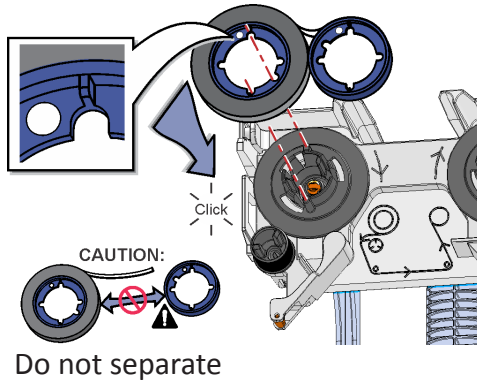

b. Load the topping foil onto the cartridge.

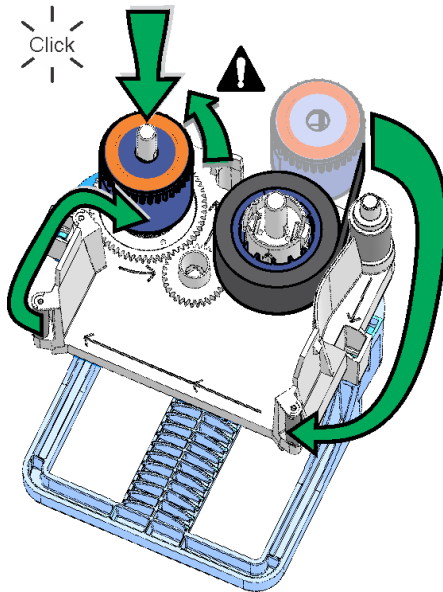
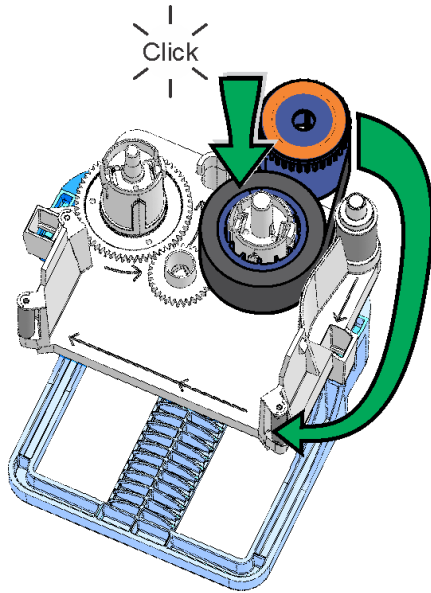

CE870 Instant Issuance System

- c. Replace the cartridges in the embosser.

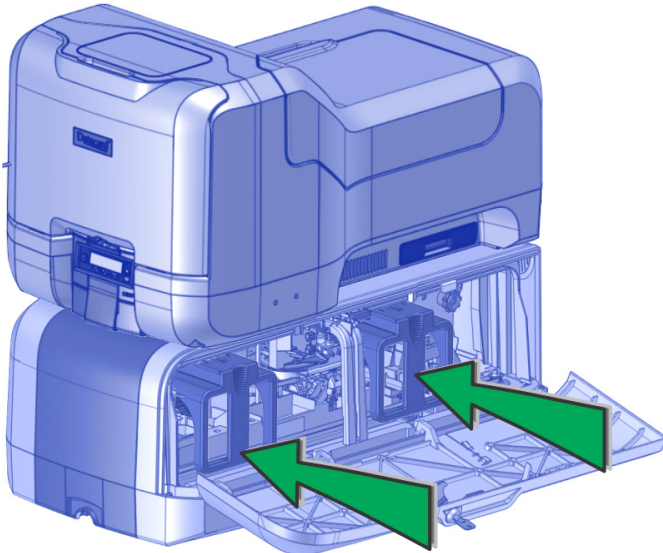

- d. Remove the print ribbon cartridge.

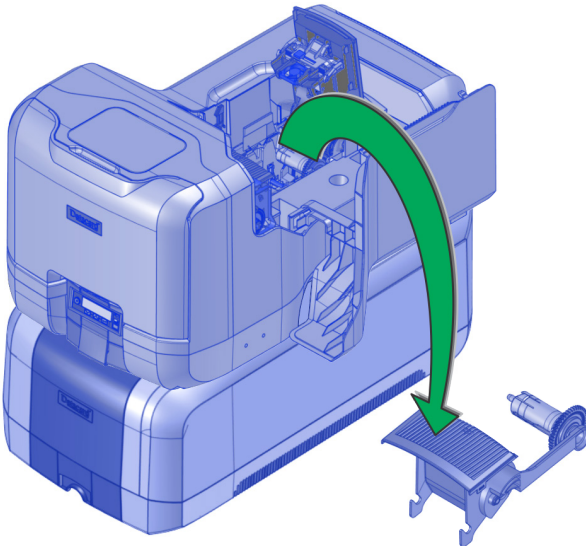

- e. Load the cleaning sleeve onto the cartridge.

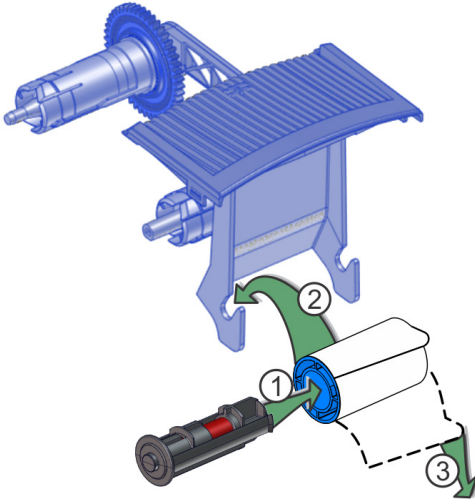

- f. If your printer is equipped with the optional printhead, load the print ribbon onto the cartridge.

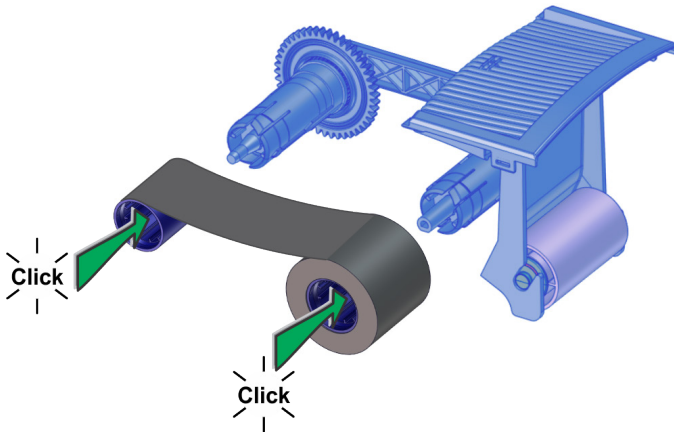

- g. Install the print ribbon cartridge in the printer.

CE870 Instant Issuance System

- h. Load the cards in the input hopper. Refer to the diagram inside the hoppers for the correct orientation.

Single Hopper Printer



Multi-Hopper Printer

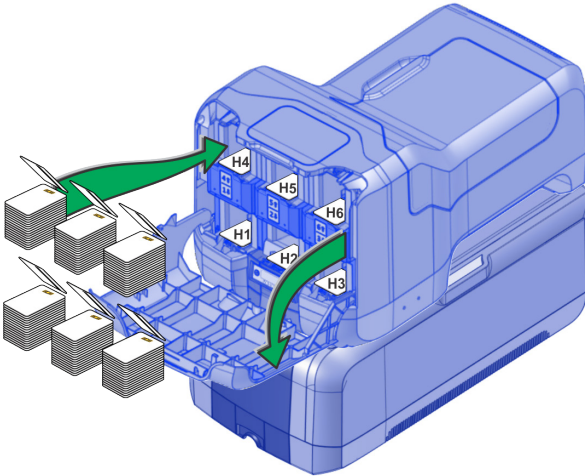

- i. Close and lock all printer and embosser doors.

8. Connect the Network Data Cable

The cable is ordered separately.

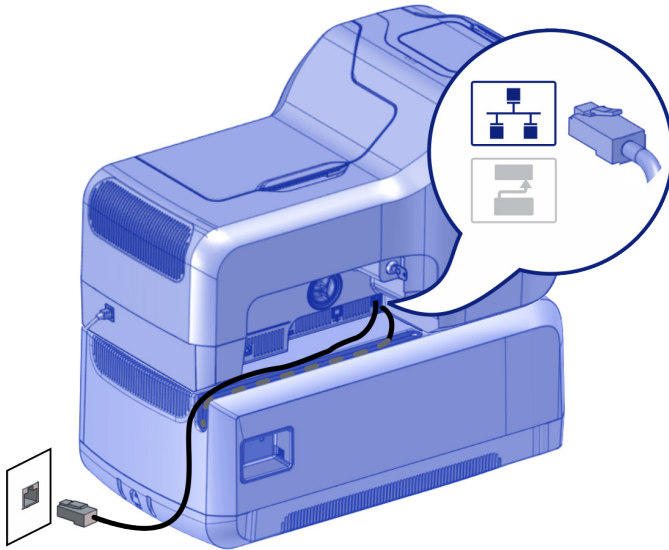

9. Power On the System

Press the power button on the front panel to power on the system.

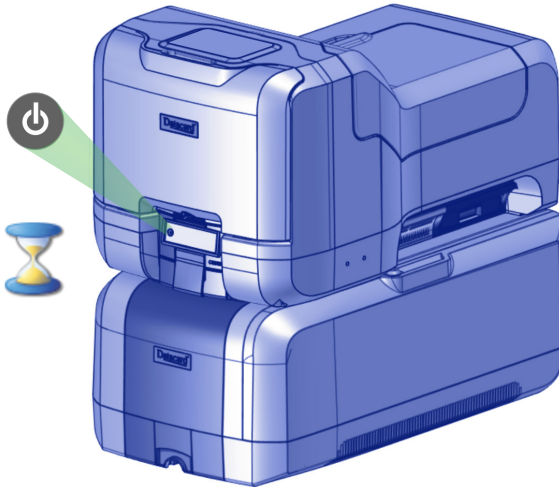

The printer may or may not require activation.

- If **Print job queue is deactivated** displays on the LCD panel, continue with “10. Activate the Printer” on page 17.

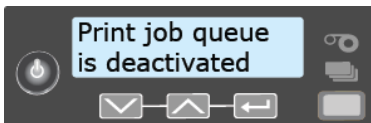

- If **Ready** displays on the LCD panel, continue with “11. Set a Static IP Address” on page 19.

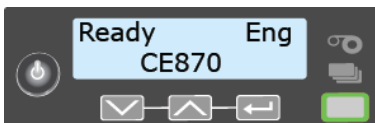

10. Activate the Printer

- a. If the printer requires activation, call 1-800-328-3996 to obtain an activation code.
- b. Have the printer and embosser serial numbers ready when you call. The printer serial number is located on the printer swingarm label. The embosser serial number is on the configuration label located inside of the embosser on the lower enclosure.

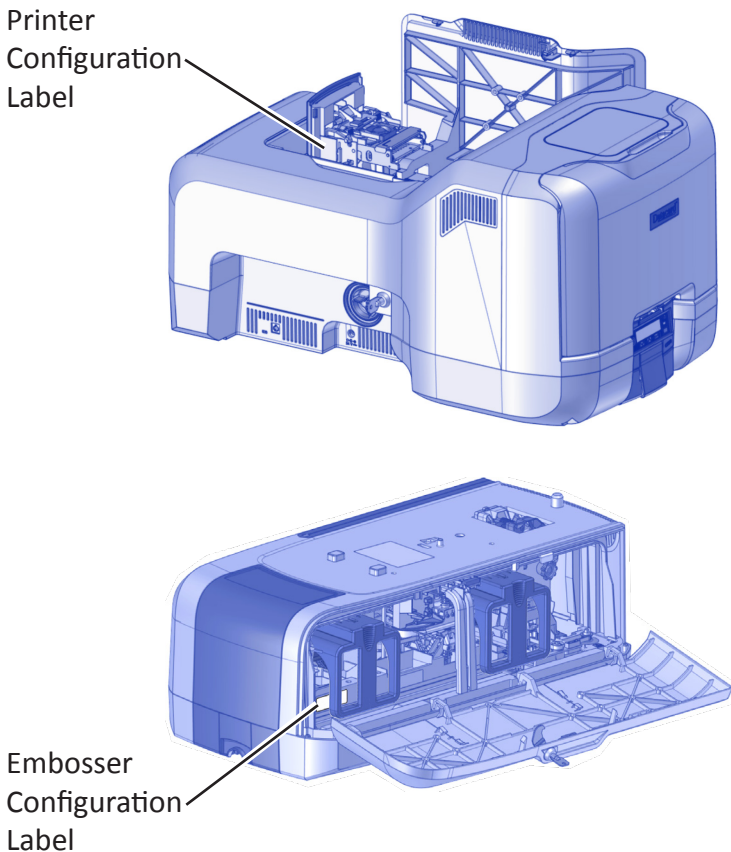

CE870 Instant Issuance System

c. Enter the activation code.

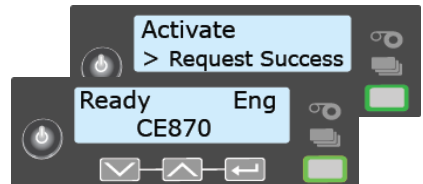
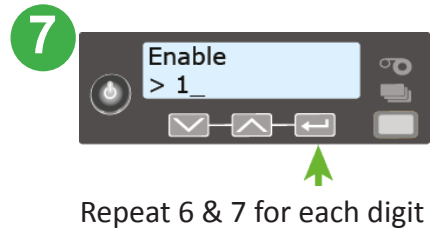
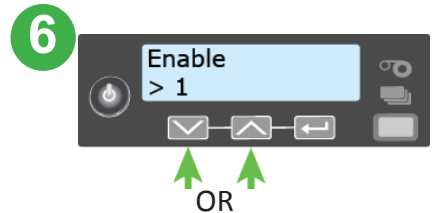
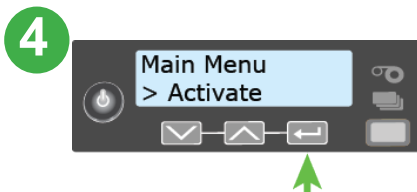
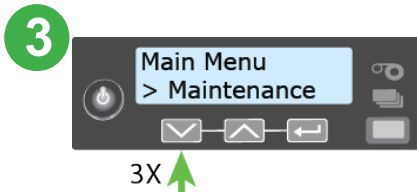
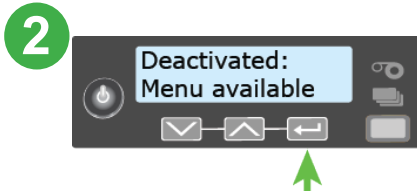
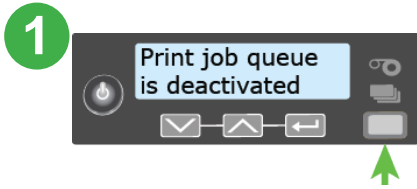

11. Set a Static IP Address

Datacard® CardWizard® issuance software requires the printer to have the same IP address at all times.

- a. Obtain the following information from your system administrator:

IP address _____

Subnet mask _____

Gateway address _____

- b. Use the front panel menu system to enter the IP address information.

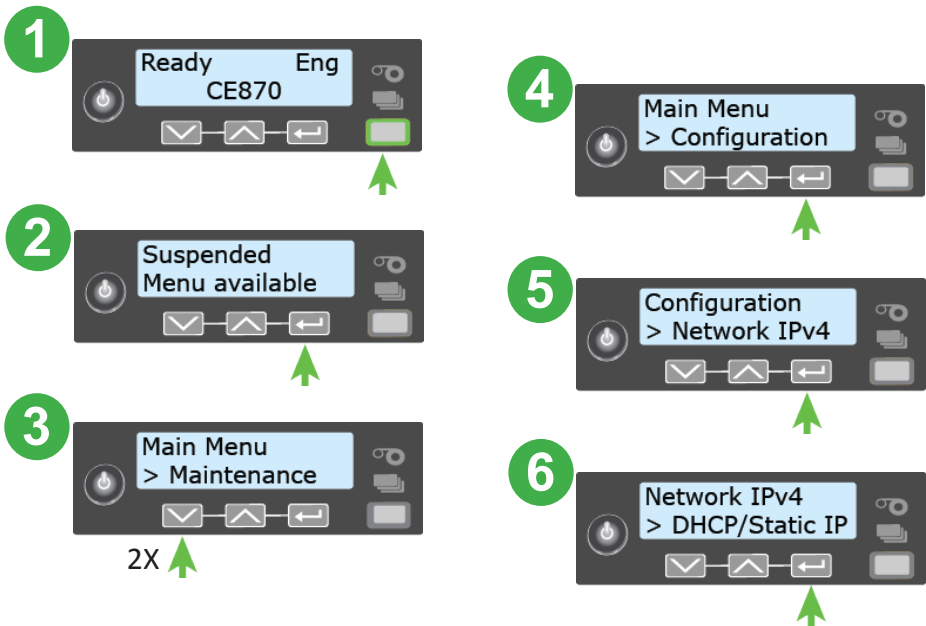

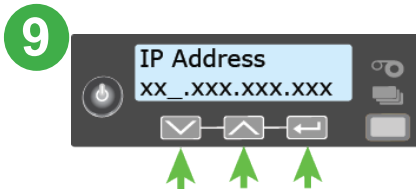
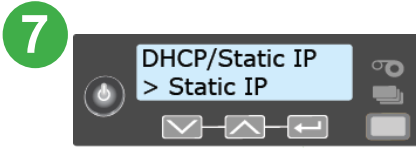

- c. Follow the same process to set the subnet mask and gateway address.

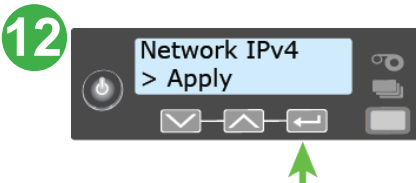
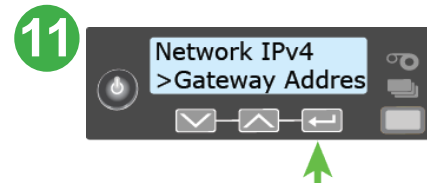
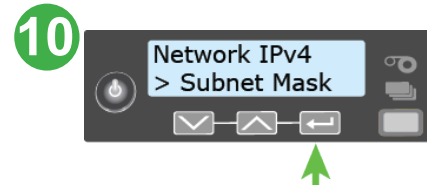

12. Print a Test Card (Optional)

- a. Using an internet browser, enter `https://xxx.xxx.xxx.xxx`, where `xxx.xxx.xxx.xxx` is the printer IP address.
- b. Log on to Printer Manager as WebAdmin.



Printer Manager

Select Language:

- English
- 日本語
- Deutsch
- Italiano
- Polski
- Español
- Português
- 한글
- 简体字
- 繁體字
- العربية

Please Log In:

Username:

No password is needed for this username.

Level: NoAccess | Hostname: G10052
Copyright 2012-2016 Entrust Datacard Corporation.

- c. Select Troubleshooting > Test Card.

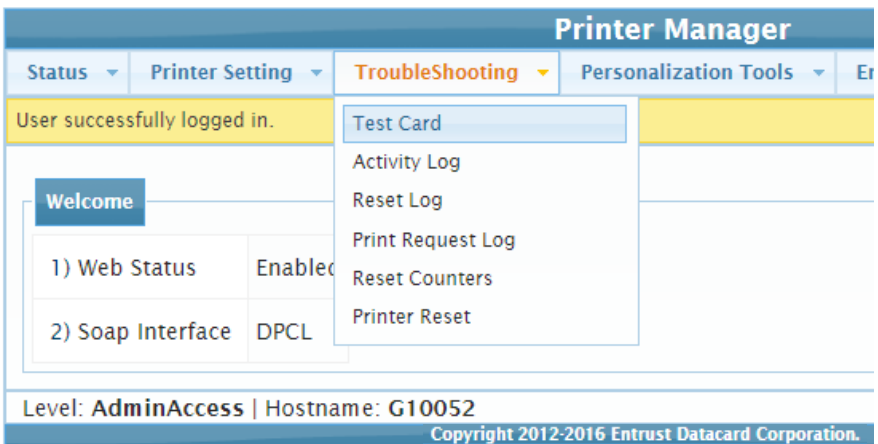

Printer Manager

Status ▾ Printer Setting ▾ **TroubleShooting** ▾ Personalization Tools ▾ Er

User successfully logged in.

Welcome

1) Web Status	Enabled
2) Soap Interface	DPCL

- Test Card
- Activity Log
- Reset Log
- Print Request Log
- Reset Counters
- Printer Reset

Level: AdminAccess | Hostname: G10052
Copyright 2012-2016 Entrust Datacard Corporation.

CE870 Instant Issuance System

- d. Select the **Emboss** test card option and the test card to run. Each test card tests the position and quality of embossed and indented characters. Refer to the printer's *Installation and Administrator's Guide* for a description of the test cards.

Note: If your printer does not have a printhead installed, do not select the **Color** check box.

The screenshot shows the 'Printer Manager' web interface. At the top, there is a navigation bar with tabs: Status, Printer Setting, Troubleshooting, Personalization Tools, Embosser, Maintenance, and Log Out. Below this is a 'Test Card' section. It contains a table for 'Test Card Print Options' with columns for 'Card Front (Page 1)' and 'Card Back (Page 2)'. The 'Emboss' option is checked in the 'Card Front' column, and 'TestCard1' is selected in a dropdown menu in the 'Card Back' column. Other options like 'Magnetic Stripe', 'Color', 'Monochrome', 'Topcoat', and 'Second Topcoat' are listed with checkboxes. At the bottom, it shows 'Level: AdminAccess | Hostname: G10052' and 'Copyright 2012-2016 Entrust Datacard Corporation.'

Printer Manager						
Status	Printer Setting	Troubleshooting	Personalization Tools	Embosser	Maintenance	Log Out
Test Card						
Test Card Print Options						
Description	Card Front (Page 1)	Card Back (Page 2)				
Input Hopper Number	1					
Emboss	<input checked="" type="checkbox"/>	TestCard1				
Magnetic Stripe		<input checked="" type="checkbox"/>				
Color	<input type="checkbox"/>	<input type="checkbox"/>				
Monochrome	<input type="checkbox"/>	<input type="checkbox"/>				
Topcoat	<input type="checkbox"/>	<input type="checkbox"/>				
Second Topcoat	<input type="checkbox"/>	<input type="checkbox"/>				

Level: AdminAccess | Hostname: G10052
Copyright 2012-2016 Entrust Datacard Corporation.

- e. Click **Run** to print the test card.

13. Next Steps

- Define the printer to CardWizard software. Refer to the *CardWizard and Card Printer Setup Guide* for information.
- Contact your system administrator to set up the rest of the system.
- Set up security, including network authorization to the printer.
- Refer to the printer's *Installation and Administrator's Guide* for detailed installation instructions.

Please complete a brief survey about your product installation experience at:

<https://www.datacard.com/datacard-product-installation-report>

WARNING: This product contains chemicals, including lead, known to the State of California to cause cancer, and birth defects or other reproductive harm.

Wash hands after handling.



WARNING: This product can expose you to chemicals including Di(2-ethylhexyl)phthalate (DEHP), which is known to the State of California to cause cancer, and Di(2-ethylhexyl)phthalate (DEHP) and Butyl benzyl phthalate (BBP), which are known to the State of California to cause birth defects or other reproductive harm. For more information, go to www.P65Warnings.ca.gov and www.datacard.com/califpropwarning.



ENTRUST

1187 Park Place
Minneapolis, Minnesota 55379
952.933.1223 • 952.933.7971 Fax
www.entrust.com

Entrust, Sigma and the hexagon design are trademarks, registered trademarks and/or service marks, and Datacard is a registered trademark and service mark, of the Entrust Corporation in the United States and other countries. All other trademarks are the property of their respective owners.

© 2012-2020. The design and information contained in these materials is protected by US and international copyright law.